

GLASSHOUSE MONTESQUIEU

WIDTH 2.80 M

ON LOW WALL OR BASEPLATE
40 OR 87 CM HIGH

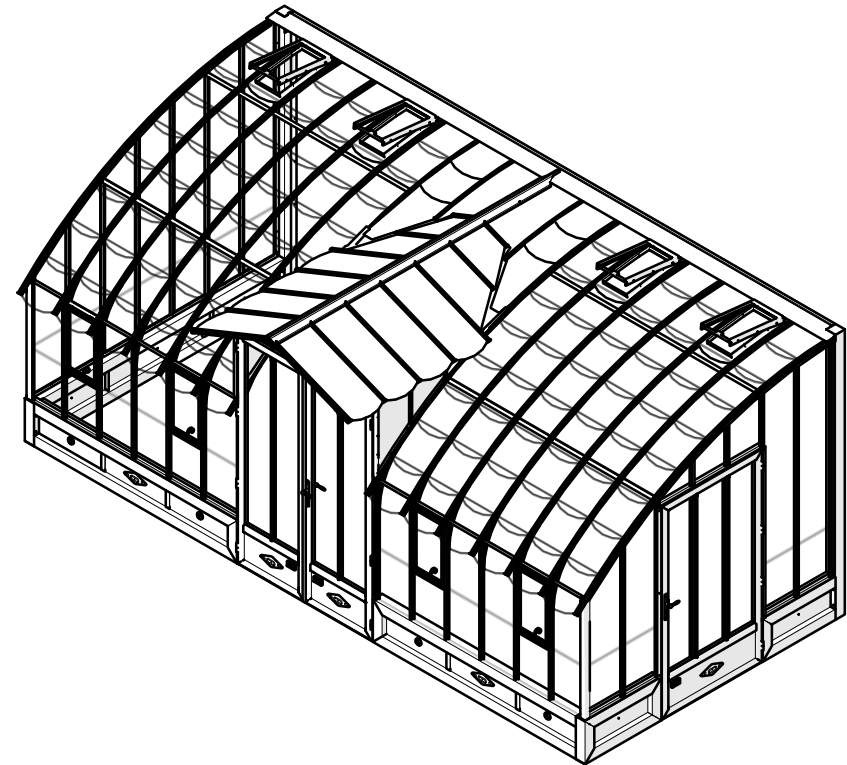
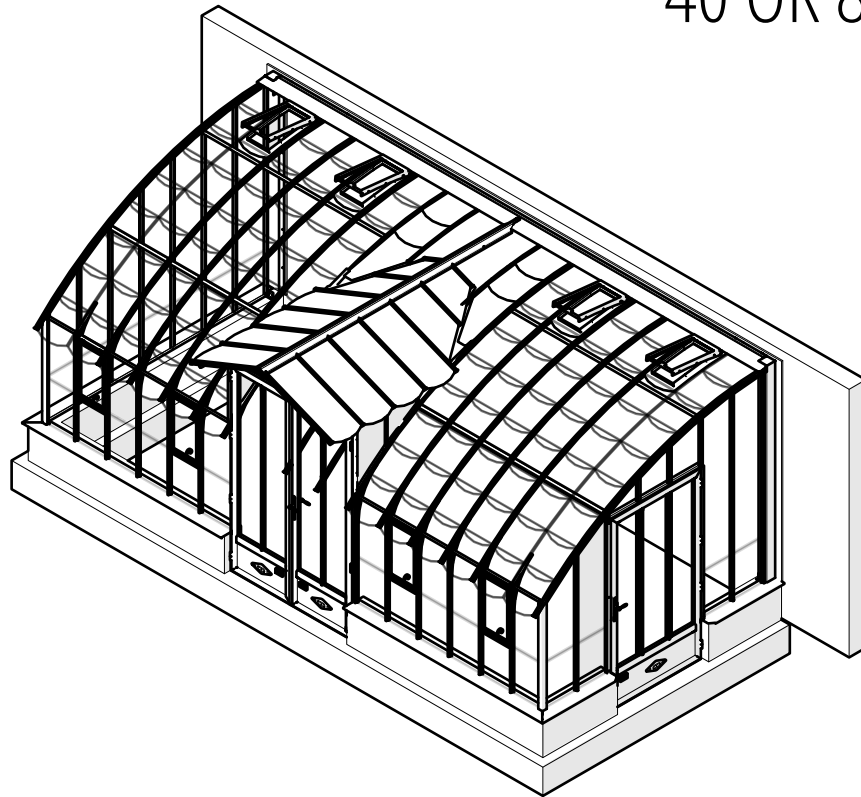

French glasshouse designer & manufacturer since 199.

CONTENTS

• Recommendations	03-04
• List of small parts	05
• List of profiles	06
• Location of the profiles	07
• Masonry plan for the wall	08
• Assembling the poles and roof ridge on the ground	09
• Positioning and fixing the aluminium coping - Glasshouse on low wall	10
• Positioning and fixing the aluminium coping and door frame - Glasshouse on low wall	11
• Masonry plan for the concrete blocks	12
• Masonry plan for the concrete frame and slab	13
• Assembling the poles and roof ridge on the ground	14
• Assembling the aluminium baseplate, the door frame and the poles with the ridge	15
• Fixing the baseplate to the ground	16
• Installing the roof ridge coping	18-19
• Installing the seal on the roof profiles	20
• Installing the wall corner profiles	21
• Installing the curved exterior roof profile	22
• Installing the front wall profile	23
• Installing the gable profile	24
• Installing the curved roof profiles of the dormer - Fixing the upper part	25
• Installing the curved roof profiles of the dormer - Fixing the lower part	26
• Installing the dormer	27-45
• Installing the curved roof profiles - Fixing the upper part	46
• Installing the curved roof profiles - Fixing the lower part	47
• Installing the roof beams	48
• Installing the door and roof windows	49
• Installing the wall windows	50
• Installing the wall and roof glazing - Ridge height 2,70 m	51
• Installing the wall and roof glazing - Ridge height 3,10 m	52
• Installing the roof glazing - Small glass panes (glass tiles)	53
• Finishing touches	54
• Shading system	55

RECOMMENDATIONS



IMPORTANT

Remember to declare your glasshouse to your insurer.

Please read the following instructions carefully before you start assembling your glasshouse.

Verify that the delivery box contains all the components referred to in this instruction manual and check their quantities.

Follow the assembly steps in the order given in this instruction manual.

Some profiles show small 3mm DIAM holes. These small holes were meant for hanging the profiles in the paint booth and are of no use for assembly itself.

SAFETY WARNINGS

Please wear safety gloves, shoes and glasses.

Follow the safety instructions for each of the other tools you will be using.

Do not assembly your glasshouse in adverse weather conditions (rain, wind, storm...).

The glasshouse should be assembled by 2 people.

Position your glasshouse on a flat level area.

For a glasshouse on a on low wall : observe the outer measurements given and the squaring of the wall (see masonry plan).

For a lean-to glasshouse : the lean-to wall must be plumb (see masonry plan).

The plastic bags and small components are not toys. Keep them away from children's reach. Keep children away from the assembly area.

Aluminium conducts electricity. The aluminium profiles should not be in contact with any source of power.

Do not store any heat-generating device in the glasshouse (barbecue, blowtorch etc...).

Do not mount or install your glasshouse over water, electricity or gas underground networks.

Do not climb on the glasshouse roof : risk of serious injuries.

In case of heavy snow : do not leave a thick layer on the roof.

MAINTENANCE TIPS

Use soapy water and a cloth to clean your glasshouse. Do not use acetone or detergents.

Use the high-pressure cleaner from a safe distance.

Lubricate the hinges, window restrictors and locks on a regular basis.

Regularly tighten up the roof wind braces. Do not leave snow or tree leaves on the roof.

CUSTOMER SERVICE & INFORMATION

Please fill in the contact form on our website www.lams-greenhouse.com

RECOMMANDATIONS

INCLUDED TOOLS AND ACCESSORIES



Combination wrench & Ø 10 socket spanner



Automatic screwdriver ends Ø 10 & cruciform



Suction cup for glazing



Translucent silicon



Gloves



Thermometer

NECESSARY TOOLS

- Spirit level
- Tape measure
- Rubber mallet
- Pair of scissors (to cut rubber seal)
- Cross point screwdriver
- Wrench Ø 8 mm (for leaf-motif moulding and logo plate)
- Wrench Ø 10 mm
- Automatic screwdriver
- Plumb bob
- Set square
- Stepladder

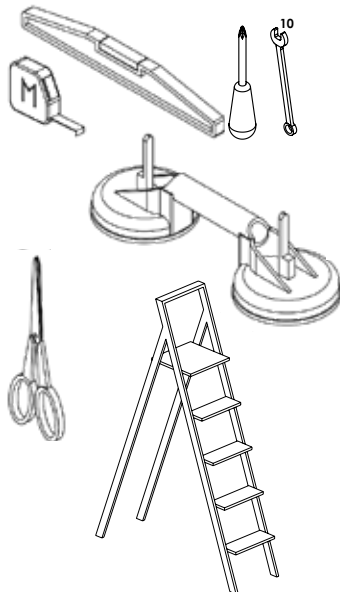

Ø 8 mm

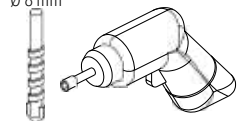

HOW TO ASSEMBLE THE SECTIONS

Hammer-head screw M6x12



Stainless steel Hex-head screw M6x12

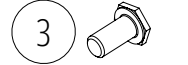

Flange nut M6



The flange nut M6 (5), the stainless steel screws (3), hammer-head and Hex-head are fundamental for the assembly.

In the first steps of assembly, use Hex-head screws (3) preferably. In the instruction manual, you will mostly see pictures of hammerhead screws (3) but you may use either hammerhead screws or Hex-head screws when (3) is specified.

You can insert hammerhead screws in the profile slots at any stage of the assembly. However, make sure hammer-head screws are properly fastened so that they don't fall off.

There's a slot in the hammerhead screw end. When the slot is perpendicular to the profile (diagram A), then the screw is in the best position.

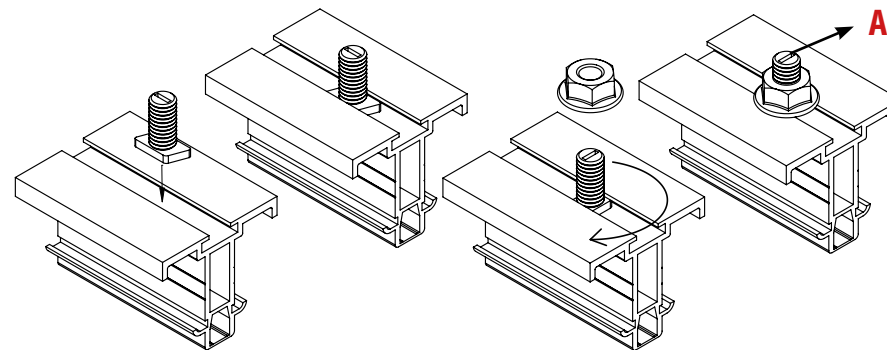

Horizontal imprint

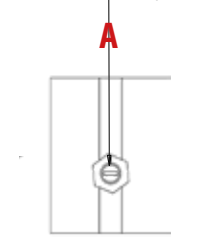



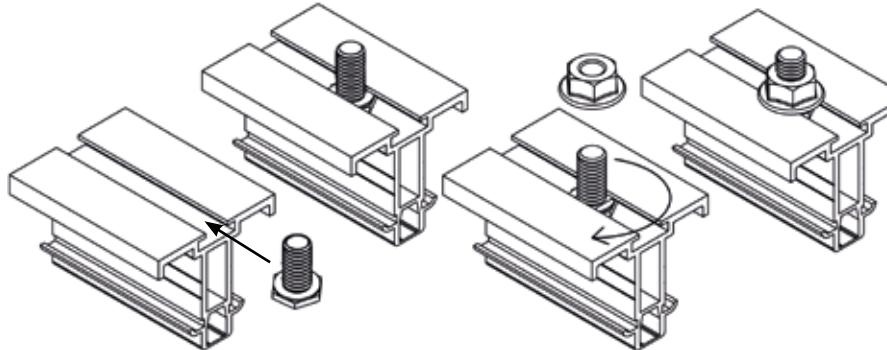











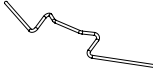







Put the Hex-head screw (3) in the profile slot so that it stays in place.



LIST OF SMALL PARTS

Part identification

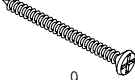
The number on the instructions enables the part to be identified in the event of an exchange between you and customer service.









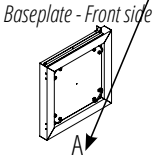

Part detail	Reference	Part detail	Reference	Part detail	Reference
<i>Pole fixing bracket</i>  1	787911	<i>Countersunk screw M6x20</i>  12	365418	<i>S glazing hooks</i>  44	365373
<i>Hex-head flange screw M6x20</i>  2	789300	<i>Leaf moulding</i>  16	363235	<i>W glazing clip</i>  SAL1	366419
<i>Hammerhead screw M6x12</i> <i>Hex-head screw M6x12</i>  3	365401 994778	<i>LAMS logo</i>  17	794995	<i>Rose moulding</i>  SAL2	364224
<i>Hammerhead screw M6x20</i>  4	608010	<i>Hex-head screw M5x8mm</i>  18	364408	<i>Wall foundry bracket</i>  SAL3	607857
<i>Flange nut M6</i>  5	789280	<i>Black plastic nut cover M5</i>  19	787551		
<i>Black plastic nut cover M6</i>  6	365483	<i>Hex-head drilling screw 6,3 x 25,4 mm</i>  26	365424	<i>Roof beam bracket</i>  SAL5	364305
<i>Ground fixing bracket</i>  7	364580	<i>T-shaped roof profile seal</i>  30	362808	<i>Front window support</i>  SAL6	
<i>Nylon dowel 8x40</i>  8	365580				
<i>Countersunk screw M5x60</i>  9	365548	<i>Pan head drilling screw 4,2x13mm</i>  43	365426		

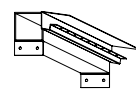
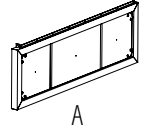
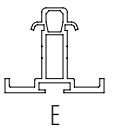
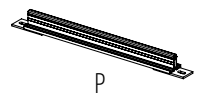
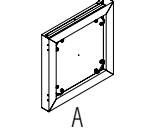
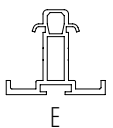
Only for the models on a low wall

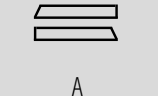
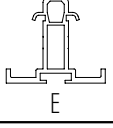
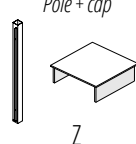
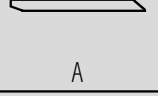
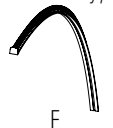
LIST OF PROFILES

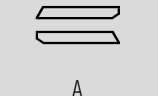
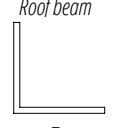
The letter on the instructions enables the part to be identified in the event of an exchange between you and customer service.

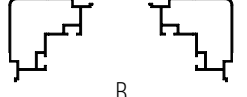
Part identification

Part detail	Dimensions	Part detail	Dimensions	Part detail	Dimensions	Part detail	Dimensions
 <p>Baseplate - Front side</p>	<p>Right and left of the dormer</p> <p>Glasshouse L. 3.80 m: L. 1066 mm Glasshouse L. 4.55 m: L. 1442 mm Glasshouse L. 5.30 m: L. 1817 mm Glasshouse L. 6.05 m: L. 2193 mm</p>	 <p>Front beam</p>	<p>Glasshouse L. 3.80 m: L. 1127 mm x2 Glasshouse L. 4.55 m: L. 1502 mm x2 Glasshouse L. 5.30 m: L. 1876 mm x2 Glasshouse L. 6.05 m: L. 2255 mm x2</p>	 <p>Roof ridge</p>	<p>Glasshouse L. 3.80 m: 3800 mm Glasshouse L. 4.55 m: 4551 mm Glasshouse L. 5.30 m: 5302 mm Glasshouse L. 6.05 m: 6053 mm</p>		
 <p>Baseplate - Gable side without door</p>	<p>L. 2806 mm</p>	 <p>T-shaped front profile</p>	<p>Ridge height 2.70 m Base H. 40 cm: L. 1120 mm Base H. 87 cm: L. 650 mm</p> <p>Ridge height 3.10 m Base H. 40 cm: L. 1513 mm Base H. 87 cm: L. 1043 mm</p>	 <p>Window stopper profile</p>	<p>Only for H. 40 cm base and the models with a ridge height of 3.10 m</p> <p>L. 358 mm</p>		
 <p>Baseplate - Gable side with door</p>	<p>Wall side: L. 788 mm Front side: L. 826 mm</p>	 <p>T-shaped gable profile</p>	<p>Ridge height 2.70 m L. 1435 mm / L. 965 mm L. 1680 mm / L. 1210 mm L. 1865 mm / L. 1395 mm L. 2010 mm / L. 1540 mm L. 2115 mm / L. 1645 mm L. 2182 mm / L. 1712 mm L. 2193 mm / L. 1723 mm Above door: L. 270 & 415 mm</p> <p>Base H. 40 cm Base H. 87 cm</p>	 <p>Door frame cover</p>	<p>Ridge height 2.70 m Base H. 40 cm: L. 1100 mm Base H. 87 cm: L. 630 mm</p> <p>Ridge height 3.10 m Base H. 40 cm: L. 1480 mm Base H. 87 cm: L. 1010 mm</p>		
 <p>Aluminium coping - Front side</p>	<p>Right and left of the dormer</p> <p>Glasshouse L. 3.80 m: L. 1202 mm Glasshouse L. 4.55 m: L. 1578 mm Glasshouse L. 5.30 m: L. 1953 mm Glasshouse L. 6.05 m: L. 2346 mm</p>	 <p>T-shaped gable profile</p>	<p>Ridge height 3.10 m L. 1818 mm / L. 1348 mm L. 1865 mm / L. 1395 mm L. 2010 mm / L. 1540 mm L. 2063 mm / L. 1593 mm L. 2498 mm / L. 2028 mm L. 2565 mm / L. 2095 mm L. 2576 mm / L. 2106 mm Above door: L. 653 & 798 mm</p> <p>Base H. 40 cm Base H. 87 cm</p>	 <p>Pole + cap</p>	<p>Ridge height 2.70 m On baseplate: L. 2666 mm On low wall H. 40 cm: L. 2266 mm On low wall H. 87 cm: L. 1796 mm</p> <p>Ridge height 3.10 m On baseplate: L. 3049 mm On low wall H. 40 cm: L. 2649 mm On low wall H. 87 cm: L. 2179 mm</p>		
 <p>Aluminium coping - Gable side without door</p>	<p>L. 2852 mm</p>	 <p>Curved interior roof profile</p>	<p>L. 3117 mm</p>	 <p>Double door</p>	<p>Ridge height 2.70 m 2 x l. 0.70 x H. 2.14 m</p> <p>Ridge height 3.10 m 2 x l. 0.70 x H. 2.54 m</p>		
 <p>Aluminium coping - Gable side with door</p>	<p>Wall side: L. 788 mm Front side: L. 826 mm</p>	 <p>Roof beam</p>	<p>Glasshouse L. 3.80 m: L. 1127 mm x2 Glasshouse L. 4.55 m: L. 1502 mm x2 Glasshouse L. 5.30 m: L. 1876 mm x2 Glasshouse L. 6.05 m: L. 2255 mm x2</p>	 <p>Roof and wall windows</p>	<p>Wall windows: L. 0.35 x H. 0.63 m</p> <p>Roof windows: L. 0.40 x H. 0.60 m</p>		
 <p>Wall corner profile (Left and Right)</p>	<p>Ridge height 2.70 m Base H. 40 cm: L. 1152 mm Base H. 87 cm: L. 682 mm</p> <p>Ridge height 3.10 m Base H. 40 cm: L. 1546 mm Base H. 87 cm: L. 1076 mm</p>	 <p>Curved exterior roof profile</p>	<p>L. 3117 mm</p>				

Only for the models on low wall

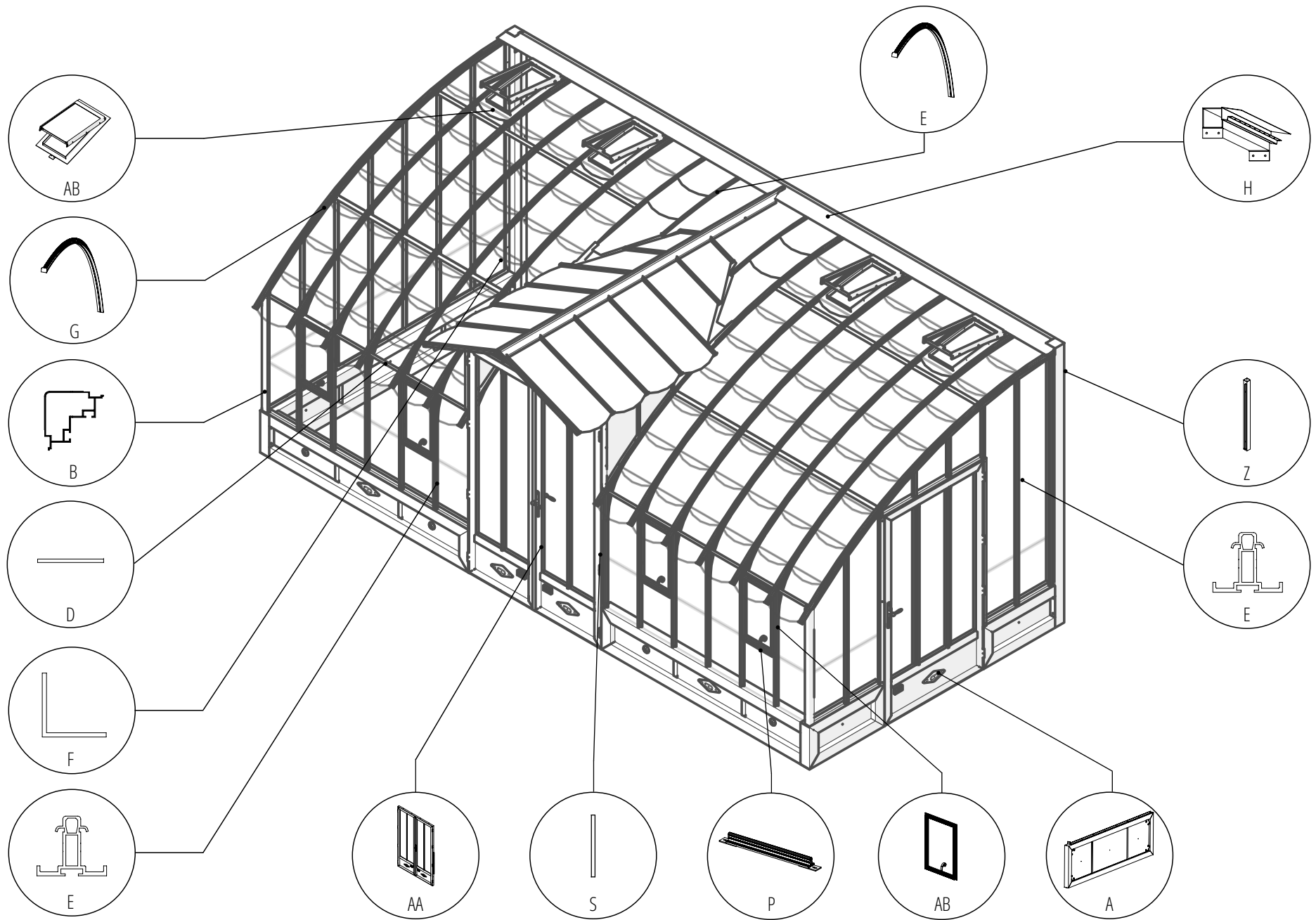

MASONRY PLAN FOR THE WALL

Please only take note of the indications for the side door on the plan below if you have chosen this option.

35 mm overhang of the aluminium coping, which allows the installation of cladding < 30 mm

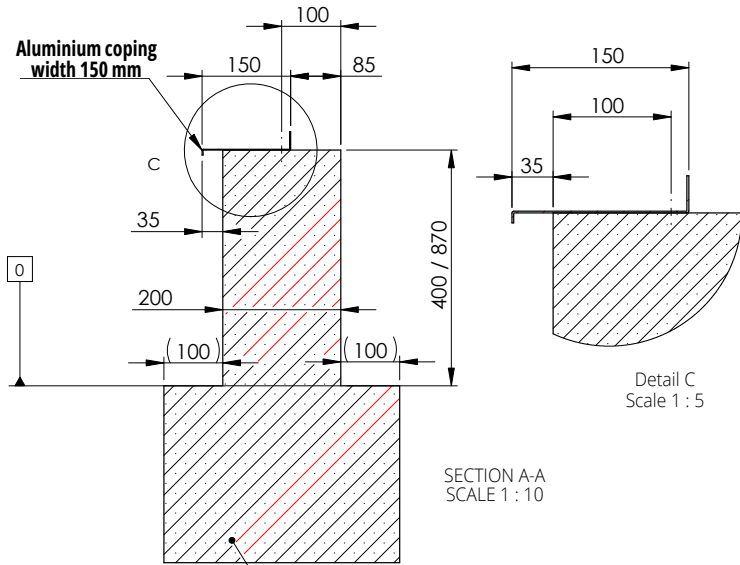

Concrete foundation: size depending on the type of ground. We recommend that you contact a local builder for the necessary size.

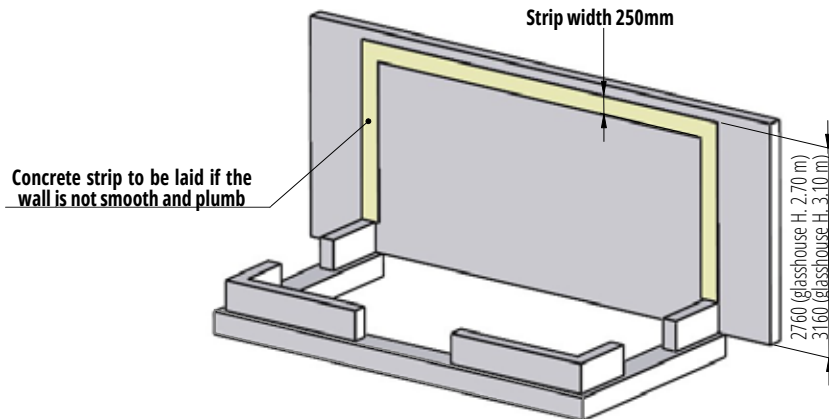

Please note that the 2nd additional left or right door, as shown on the plan below, is optional.

View from above

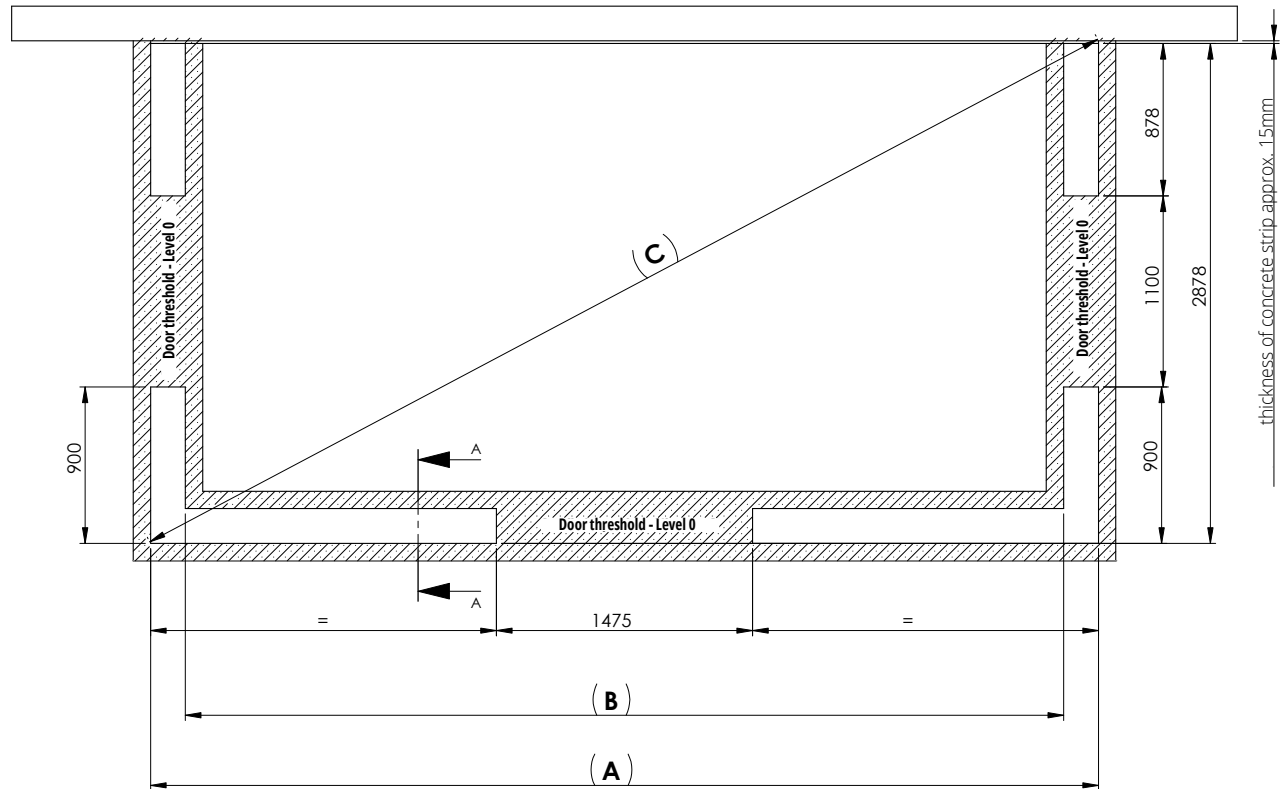

Glasshouse length	3.80 m	4.55 m	5.30 m	6.05 m
Measure A (mm)	3954	4705	5456	6207
Measure B (mm)	3554	4305	5056	5807
Measure C (mm)	4890	5515	6169	6842

ASSEMBLING THE POLES AND ROOF RIDGE ON THE GROUND

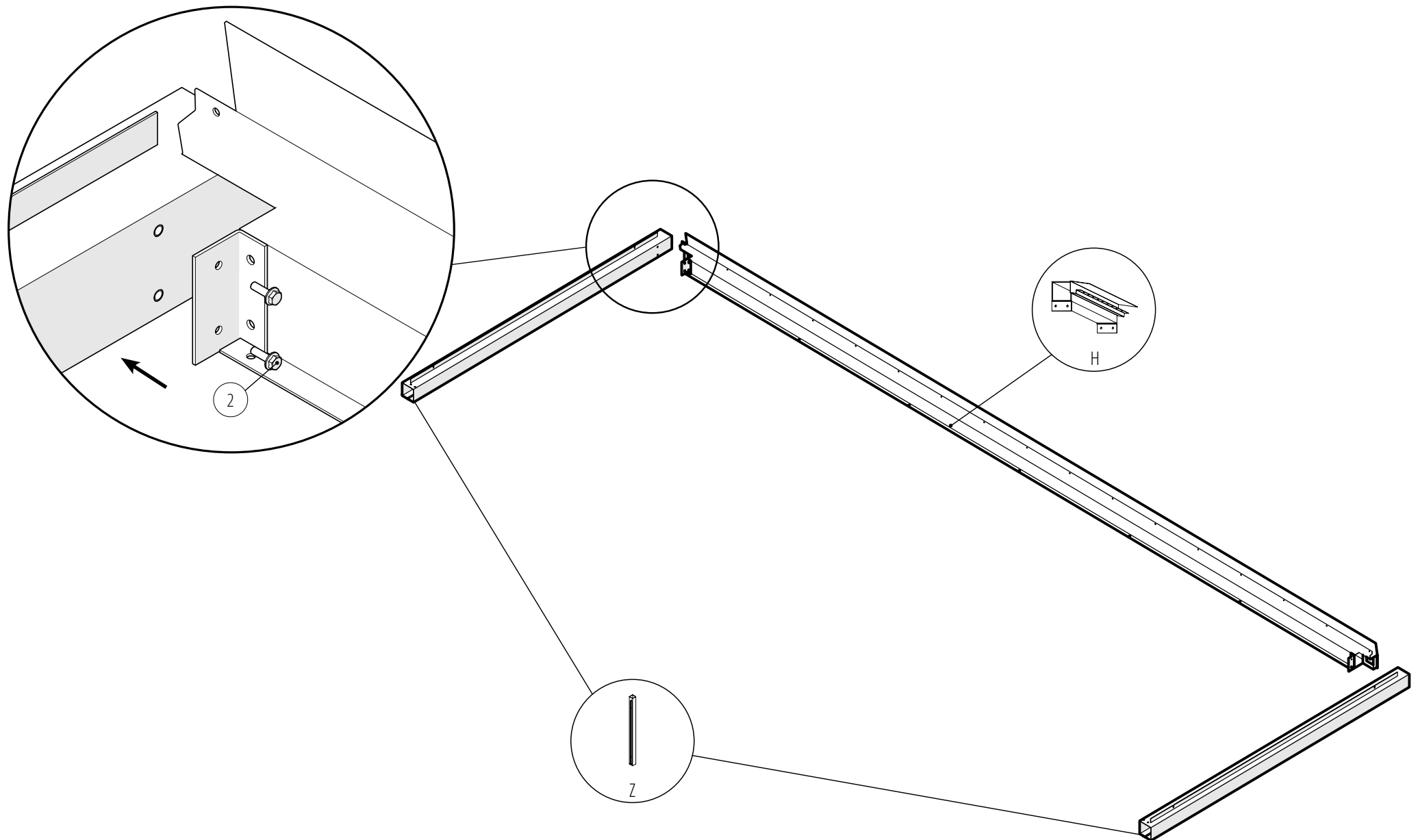

POSITIONING AND FIXING THE ALUMINIUM COPING - GLASSHOUSE ON LOW WALL

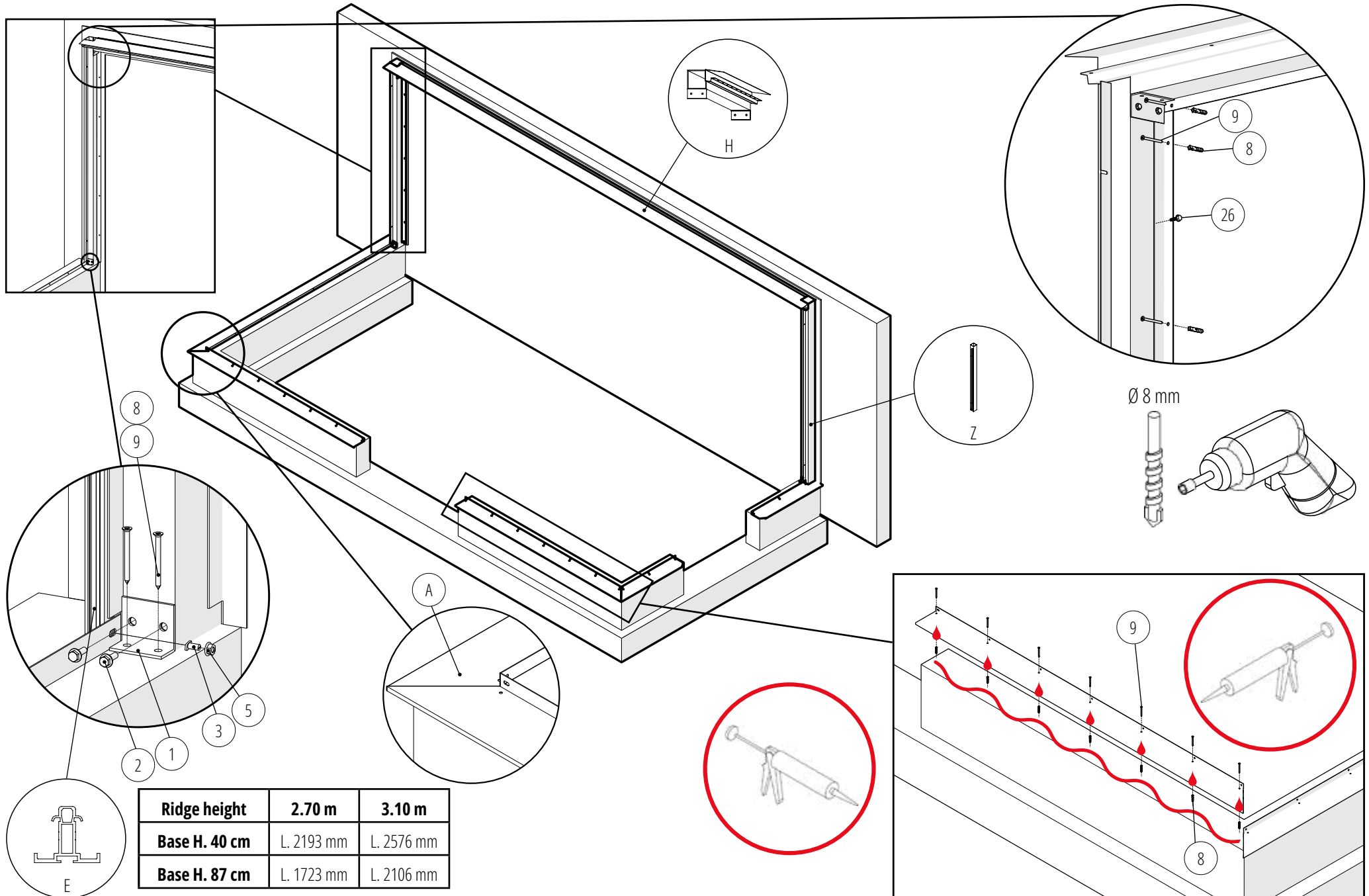

POSITIONING AND FIXING THE ALUMINIUM COPING AND DOOR FRAME - GLASSHOUSE ON LOW WALL

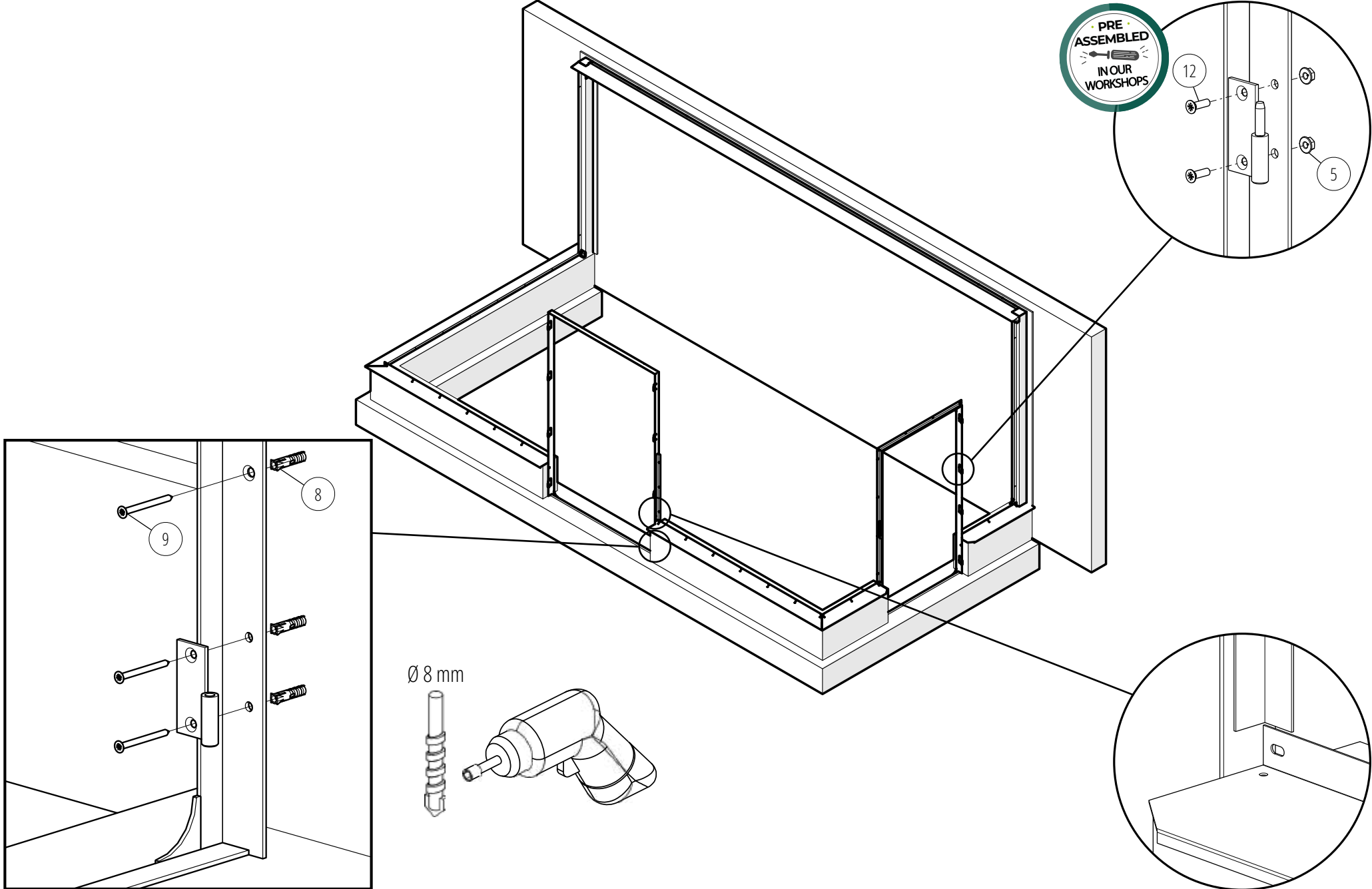

MASONRY PLAN FOR THE CONCRETE FRAME AND SLAB

Please only take note of the indications for the side door on the plan below if you have chosen this option.

Please note that the additional left and right door on the plan below are optional.

View from above

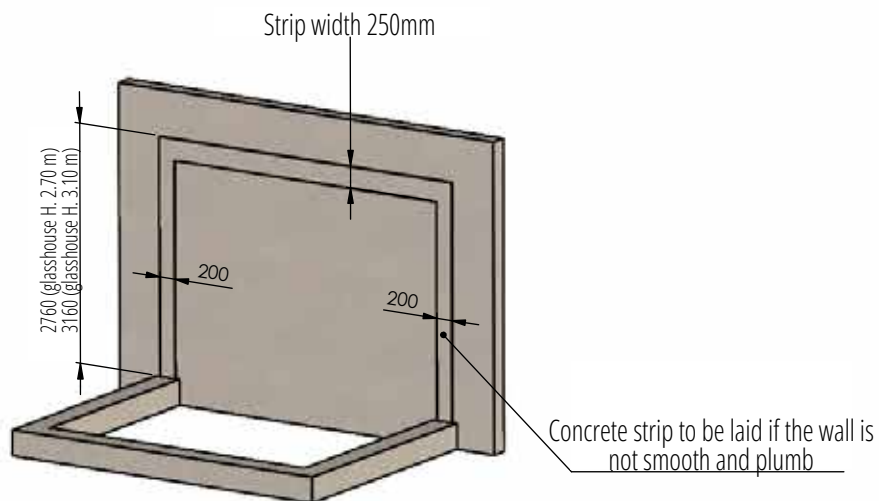
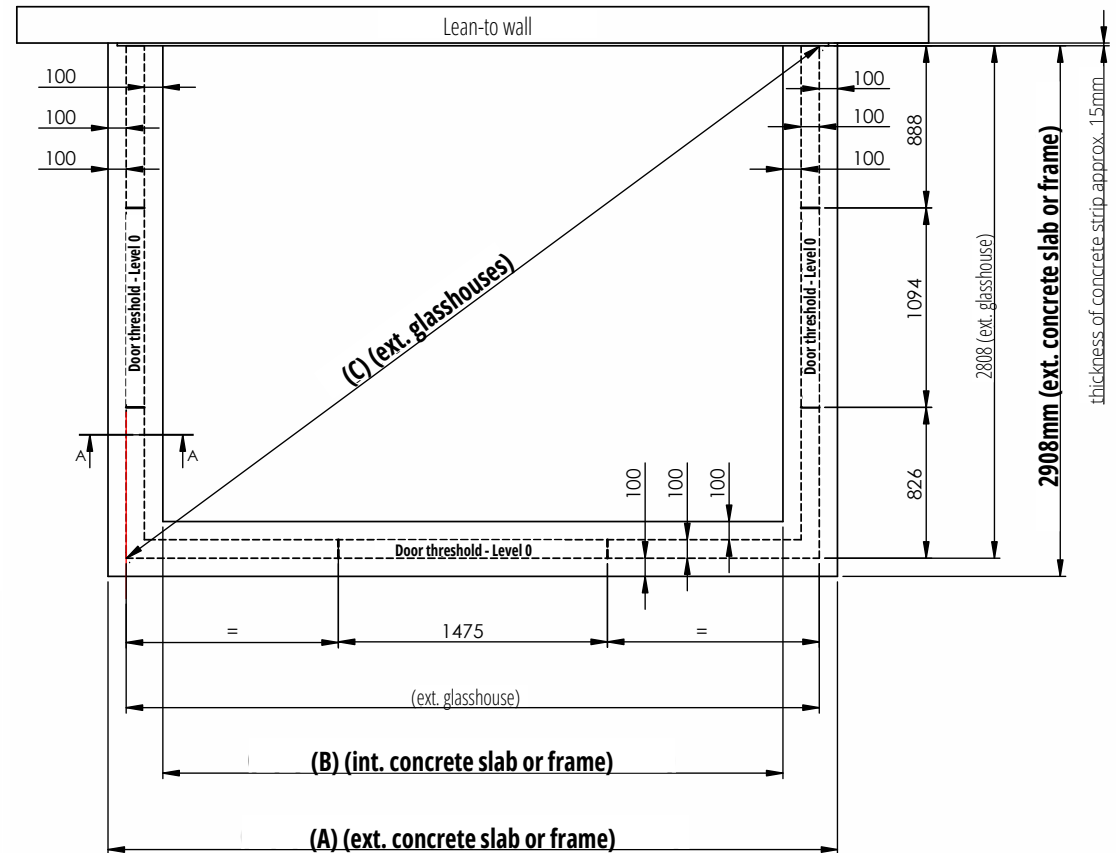
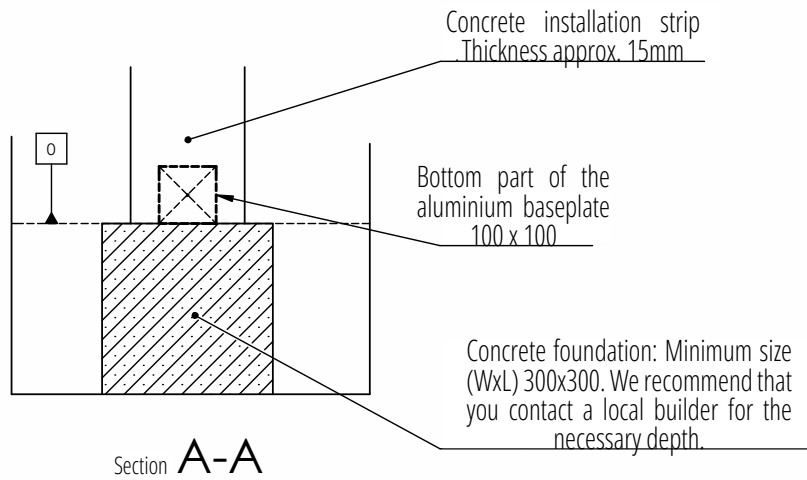

Glasshouse length	3.80 m	4.55 m	5.30 m	6.05 m
Measure A (mm)	4000	4751	5502	6253
Measure B (mm)	3400	4151	4902	5653
Measure C (mm)	4724	5347	5998	6670

ASSEMBLING THE POLES AND ROOF RIDGE ON THE GROUND

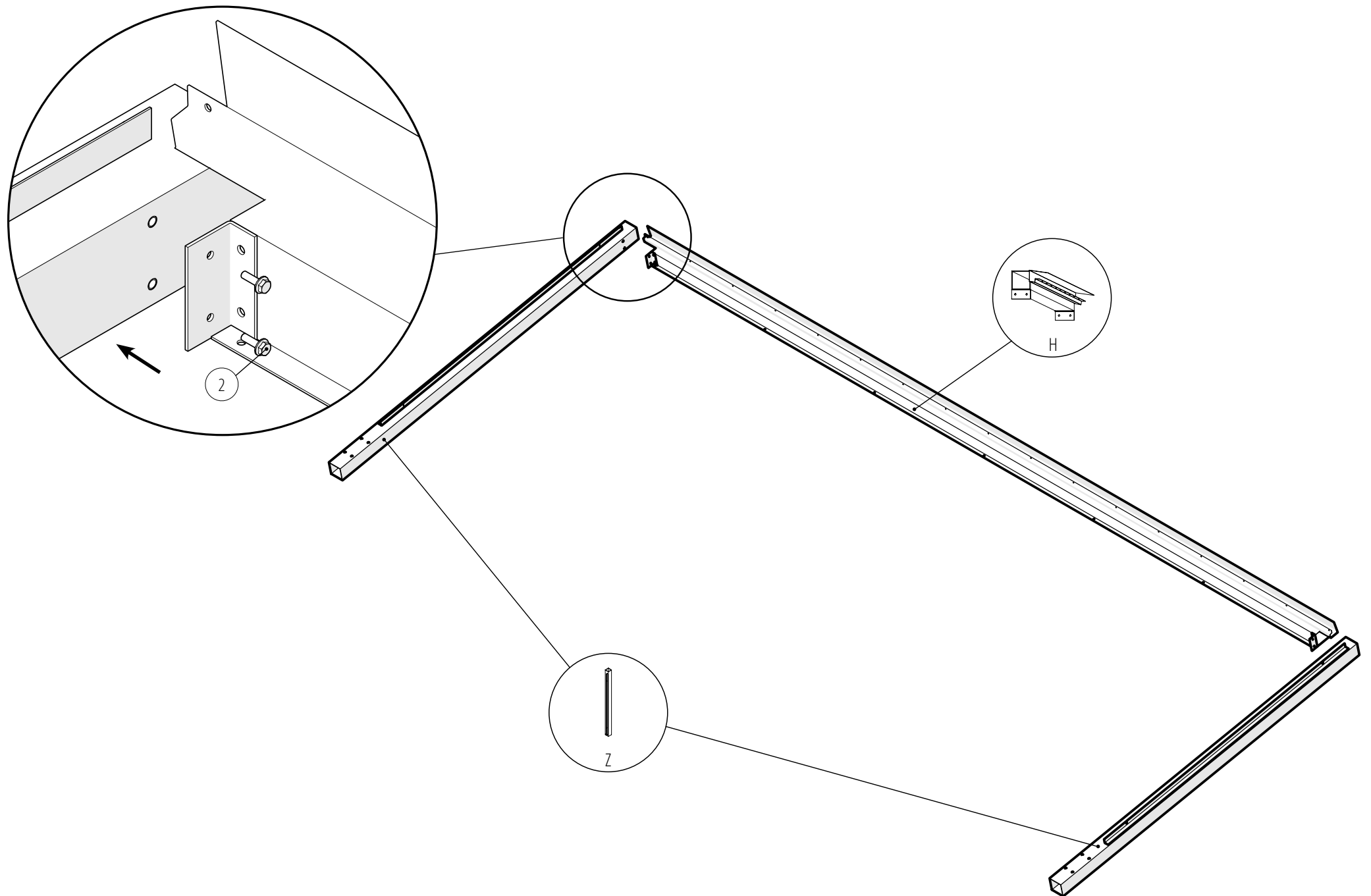

ASSEMBLING THE ALUMINIUM BASEPLATE, THE DOOR FRAME AND THE POLES WITH THE RIDGE

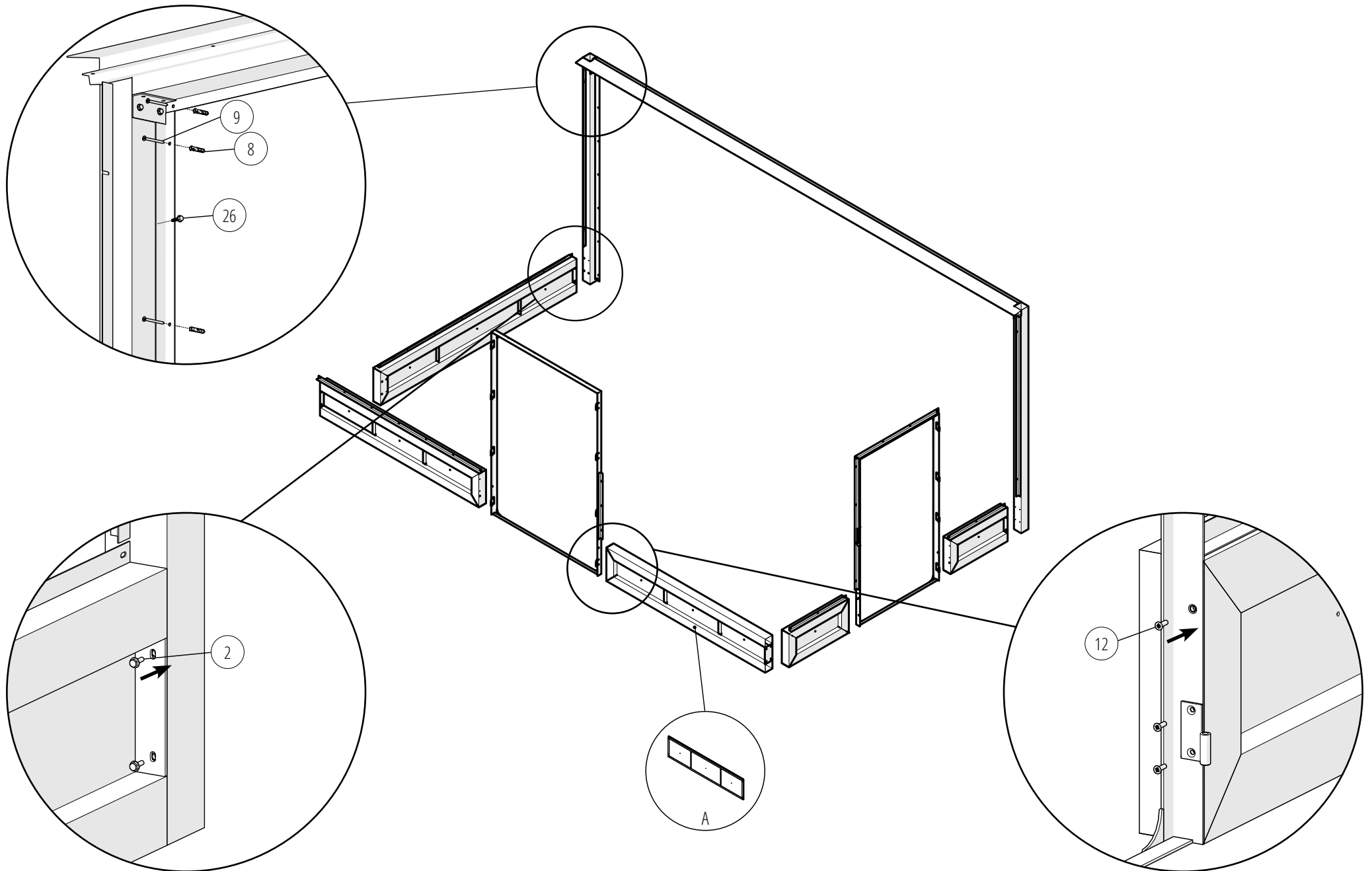

FIXING THE BASEPLATE TO THE GROUND

Fixing the brackets to the ground and to the lower part of the aluminium baseplate.

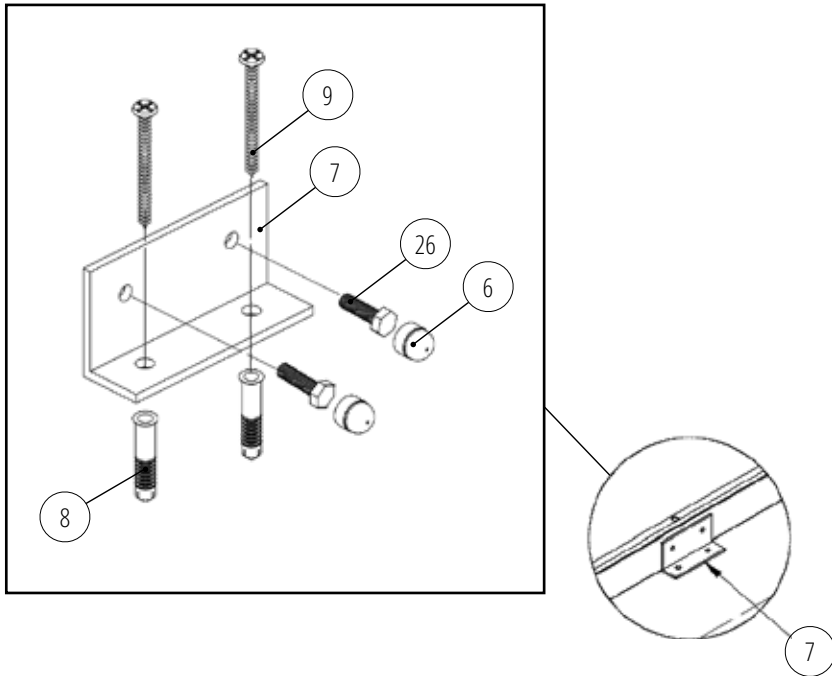

It is important that the 2 diagonales of the glasshouse are equal to obtain the necessary squareness.

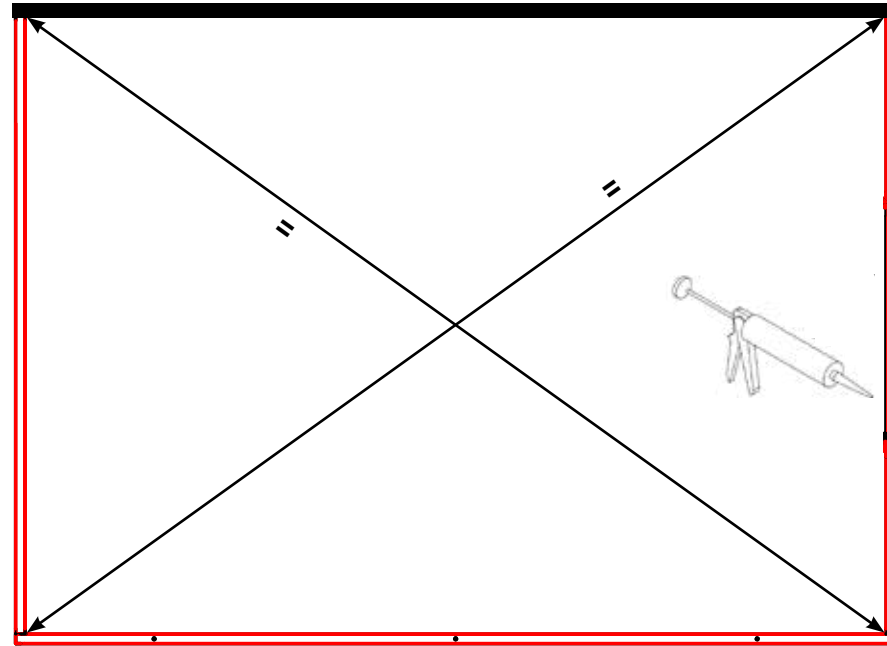

After fixing the brackets, silicone the lower part of the inside of the glasshouse.

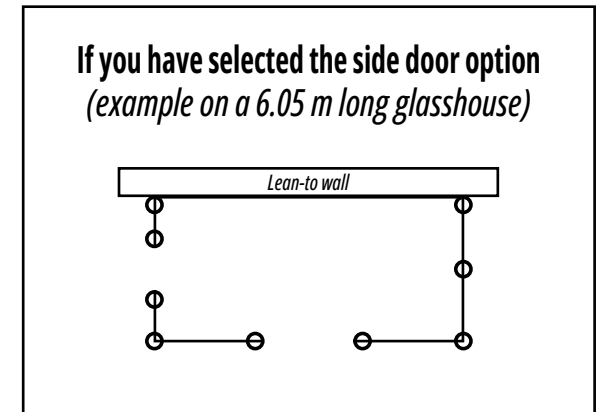
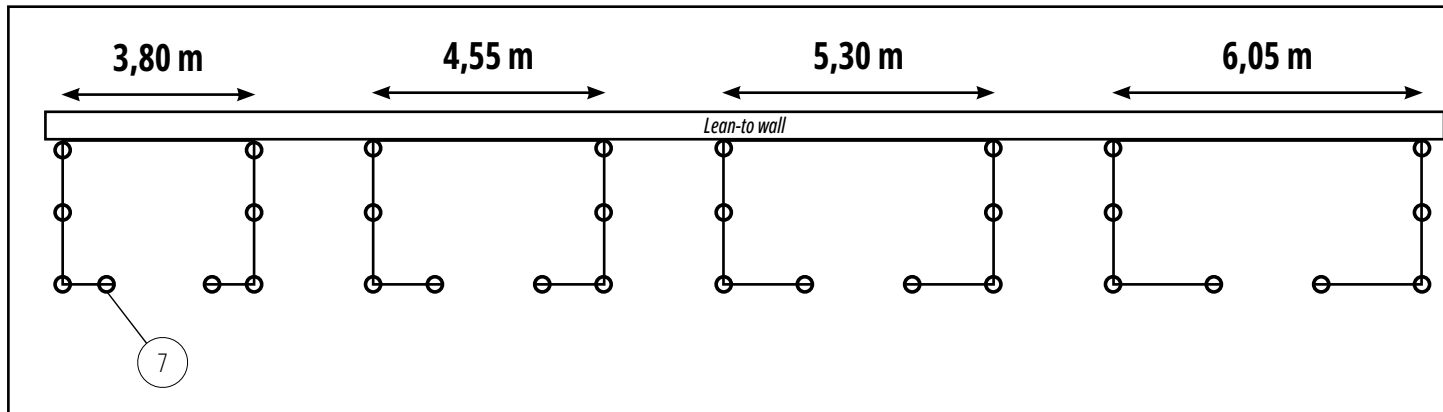



**THE FOLLOWING ASSEMBLY STEPS APPLY FOR
BOTH GLASSHOUSES ON A LOW WALL AND ON
AN ALUMINIUM BASEPLATE**

INSTALLING THE ROOF RIDGE COPING

Installation of the ridge coping is optional but strongly recommended for a better seal.

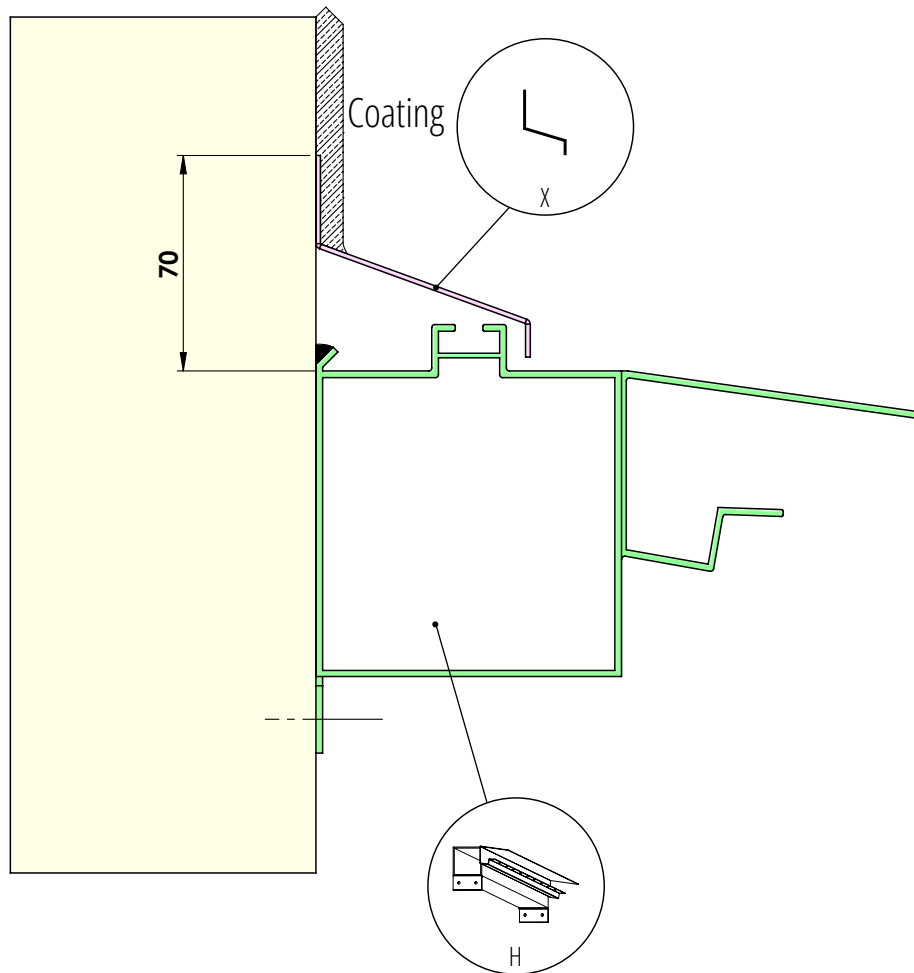

- 1 Mark the location of the coping as shown on the attached drawing (70 mm).
- 2 Lay out the coping and mark the drilling points. If one of the copings is too long for the length of your glasshouse, don't hesitate to cut it. We recommend that you leave the aluminium coping protruding by at least 1 cm on each side of the ridge.
- 3 Slit the coping every 8 to 10 cm using wire cutters.
- 4 Make the holes in the wall.
- 5 Apply silicone to the back of the coping.
- 6 Position and fix the coping to the wall using the dowels (8) and screws (9).



INSTALLING THE ROOF RIDGE COPING

- 7 If you want to reinforce the waterproofing, apply a coating (i.e plaster) to the coping.



INSTALLING THE SEAL ON THE ROOF PROFILES

To simplify installation, we recommend that you position the seal on the roof profiles before installing them on the glasshouse (reminder on the relevant pages provided). We recommend that you immerse your hands in soapy water to make fitting easier. Lay the seal along the roof profiles and trim off any excess with a pair of scissors.

Please note that the seal only needs to be positioned on the roof profiles and not on the wall profiles.

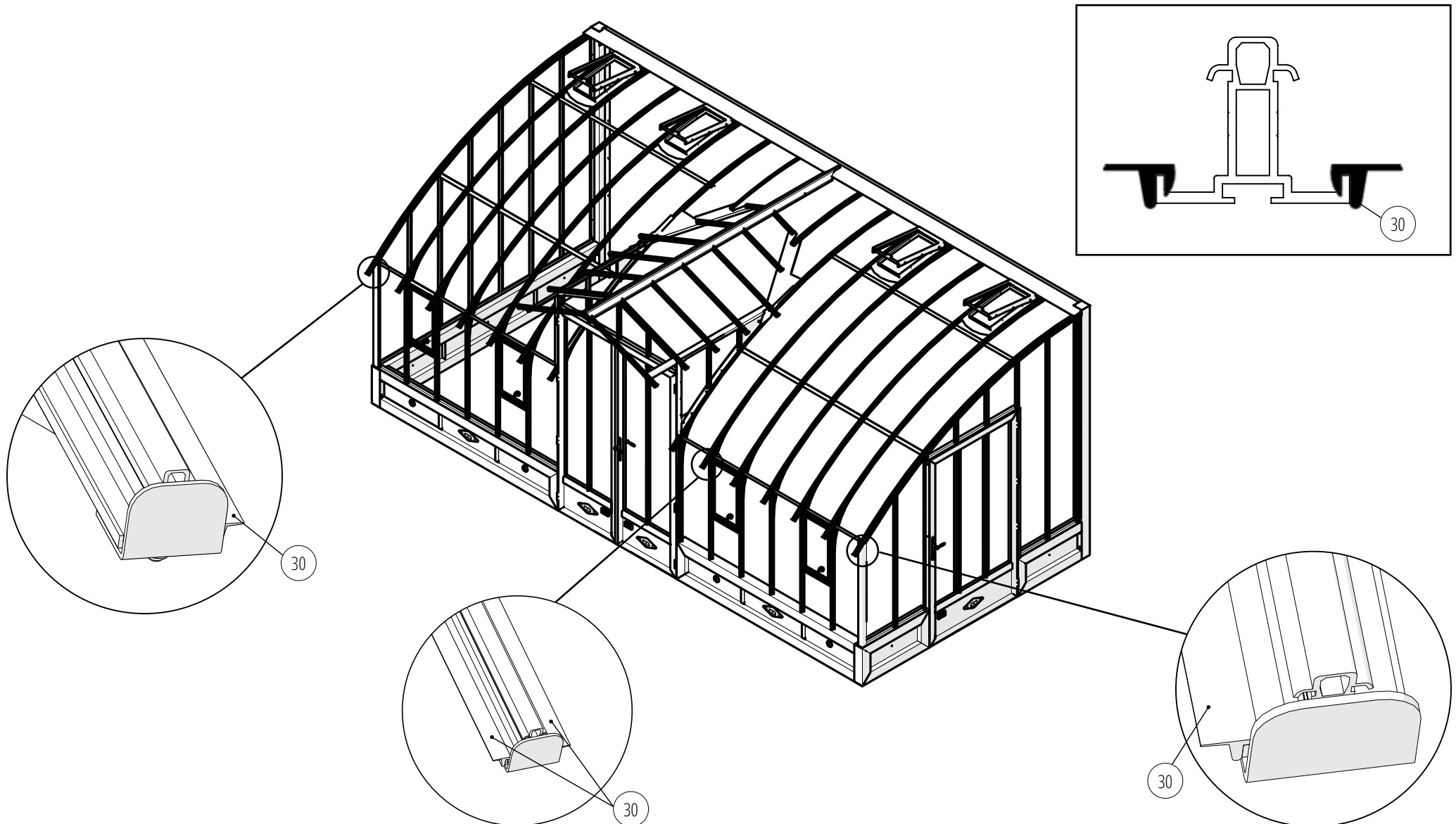

INSTALLING THE WALL CORNER PROFILES

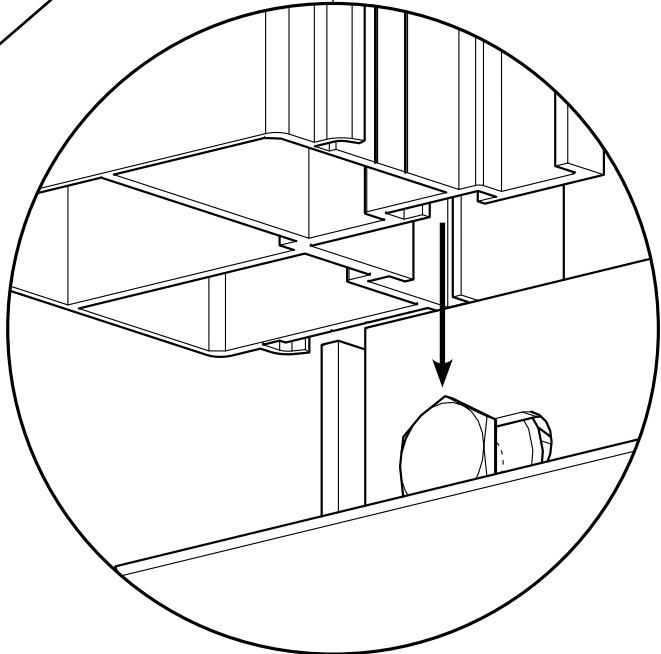
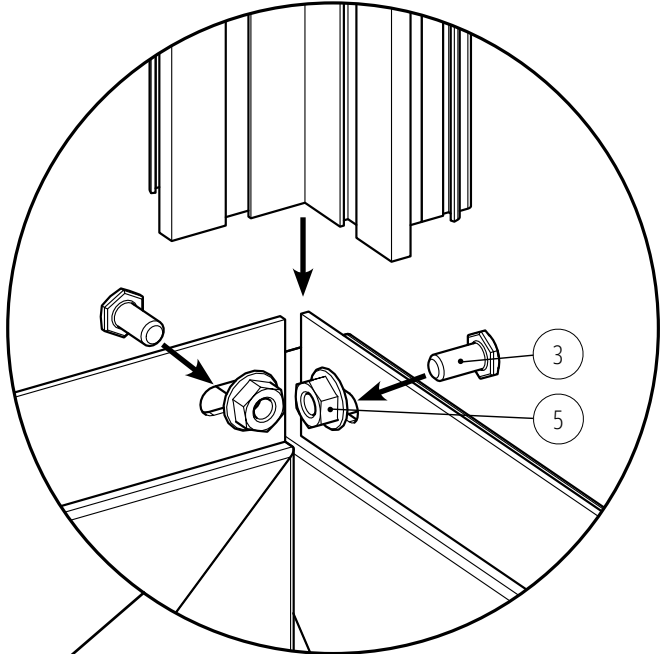
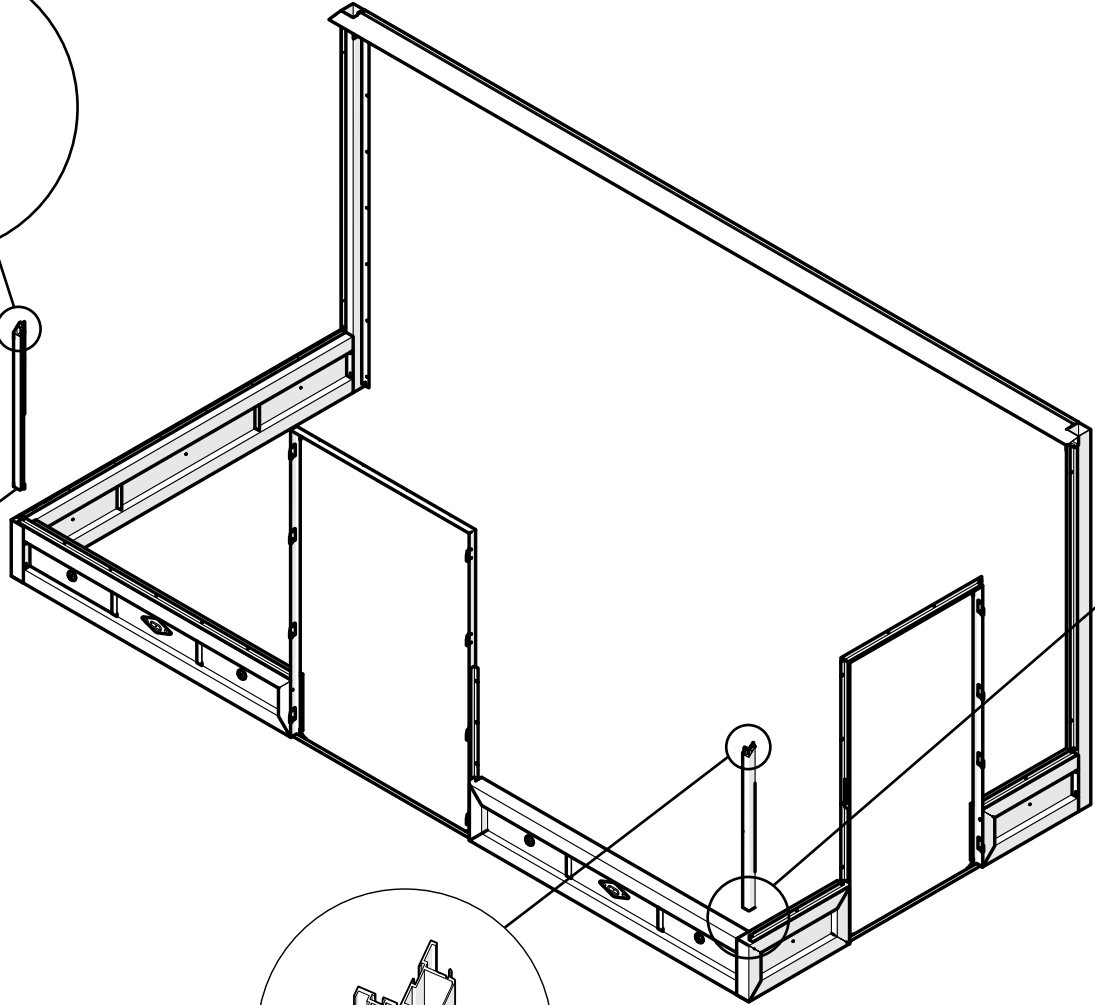
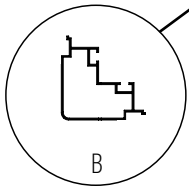
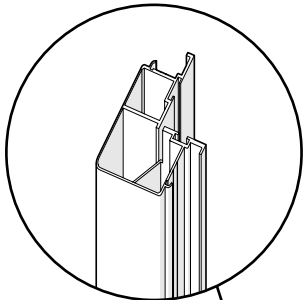

INSTALLING THE CURVED EXTERIOR ROOF PROFILE

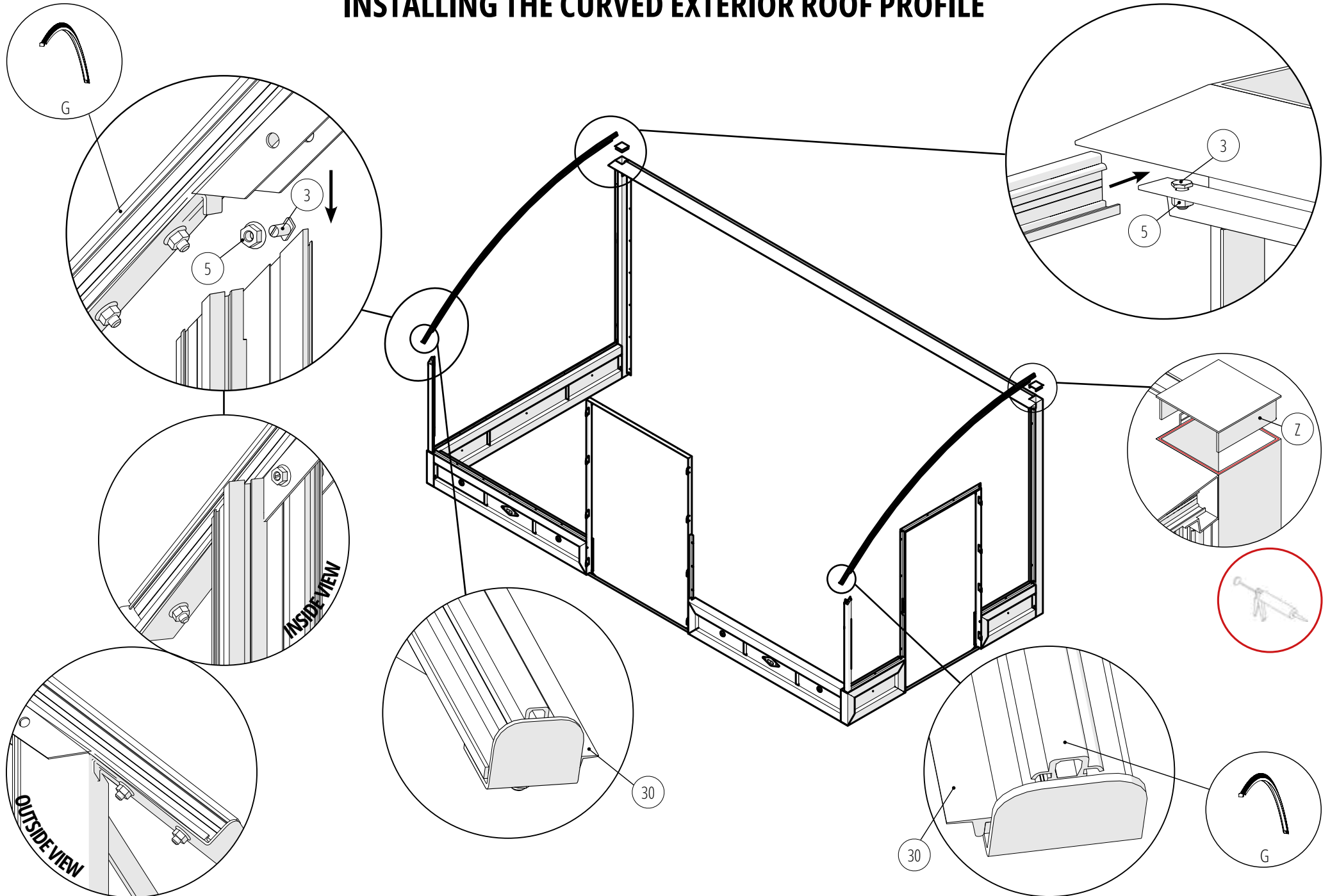

INSTALLING THE FRONT WALL PROFILE

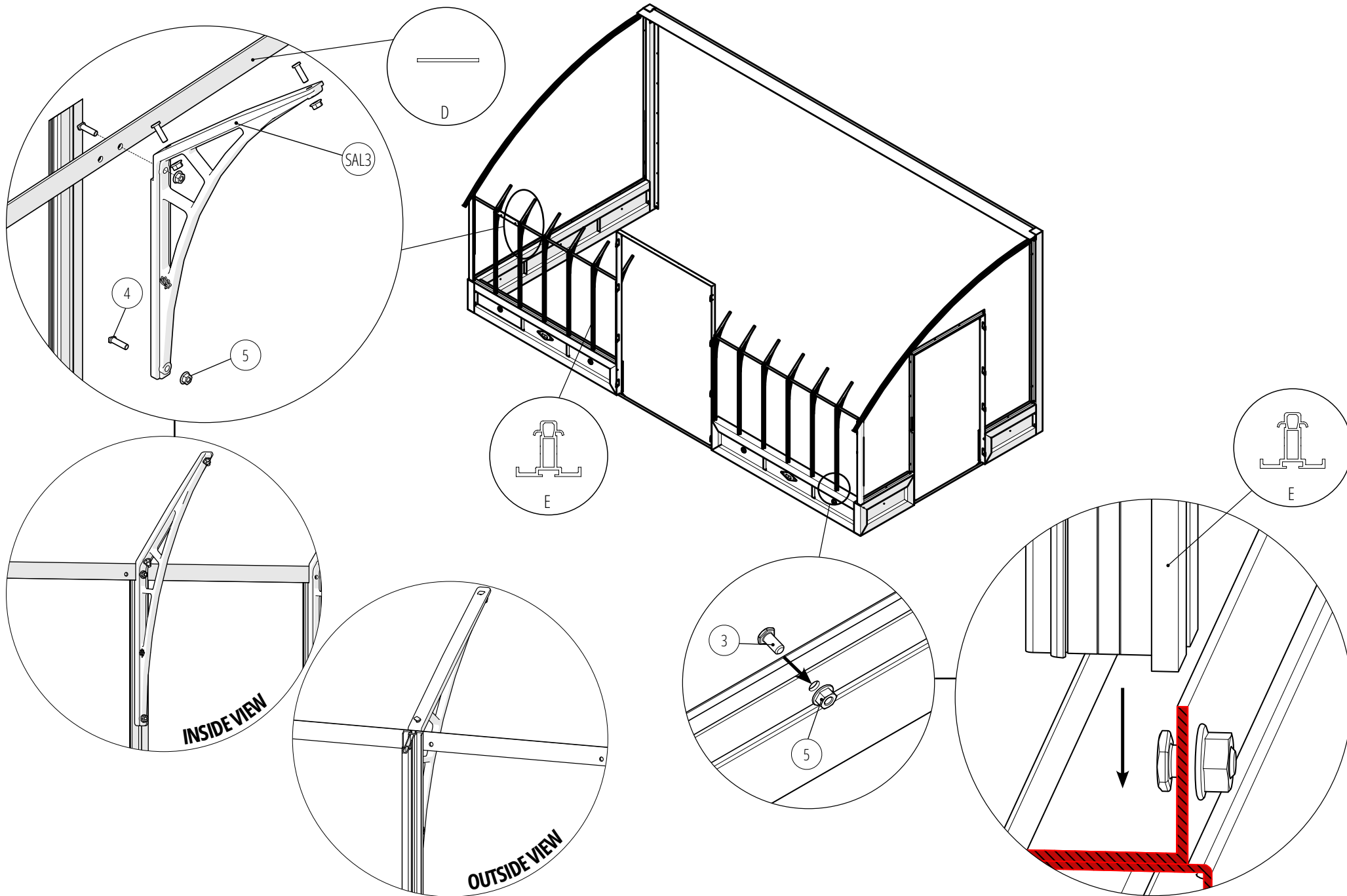

INSTALLING THE GABLE PROFILE

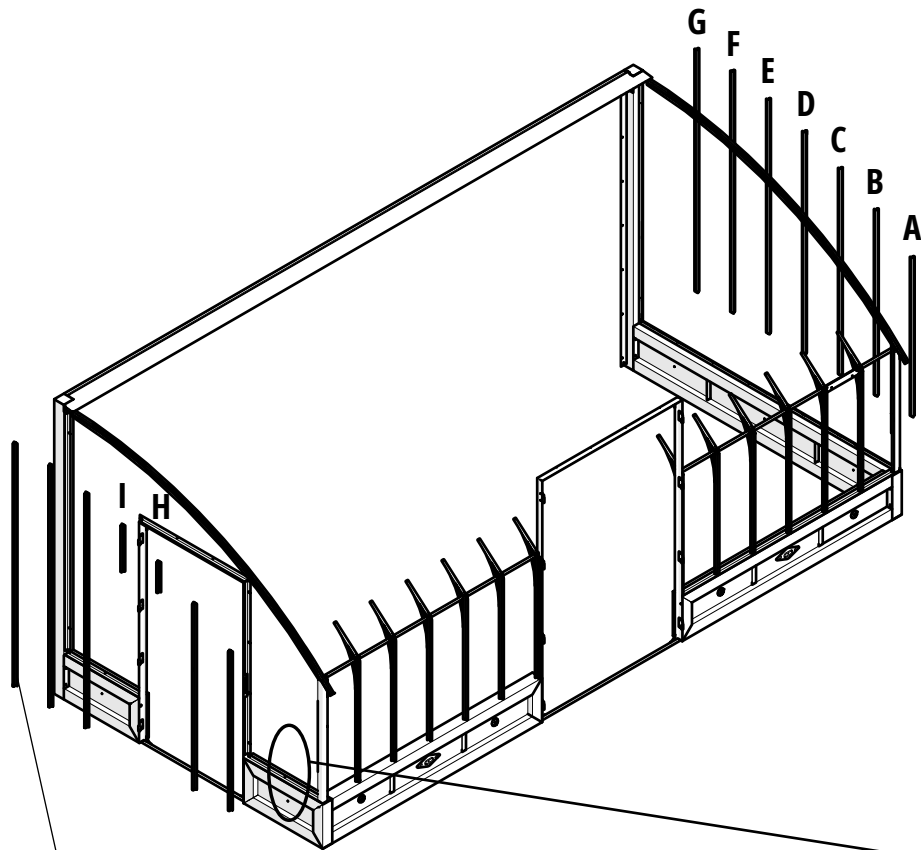

Ridge height 2.70 m							
LETTER	A	B	C	D	E	F	G
Base H. 40 cm	1435 mm	1680 mm	1865 mm	2010 mm	2115 mm	2182 mm	2193 mm
Base H. 87 cm	965 mm	1210 mm	1395 mm	1540 mm	1645 mm	1712 mm	1723 mm

Above door if optional side door	
H	I
270 mm	415 mm

Ridge height 3.10 m							
LETTER	A	B	C	D	E	F	G
Base H. 40 cm	1818 mm	1865 mm	2010 mm	2063 mm	2498 mm	2565 mm	2576 mm
Base H. 87 cm	1348 mm	1395 mm	1540 mm	1593 mm	2028 mm	2095 mm	2106 mm

Above door if optional side door	
H	I
653 mm	798 mm

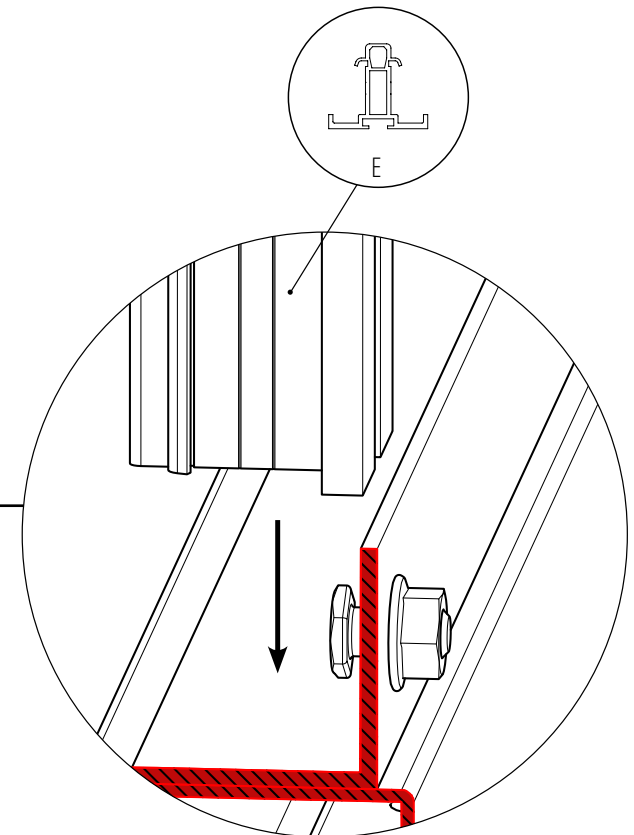
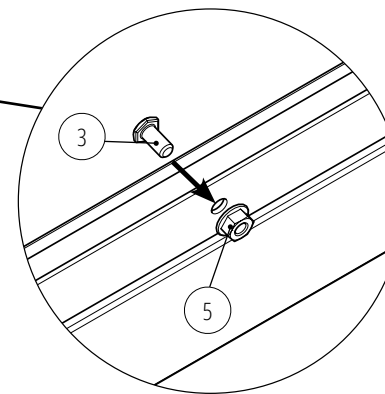
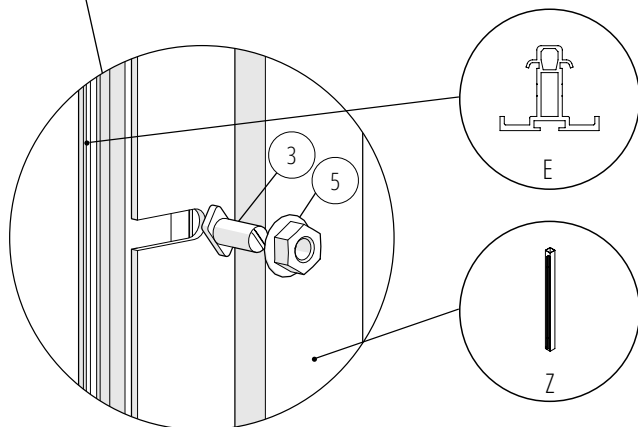

INSTALLING THE CURVED ROOF PROFILES OF THE DORMER - FIXING THE UPPER PART

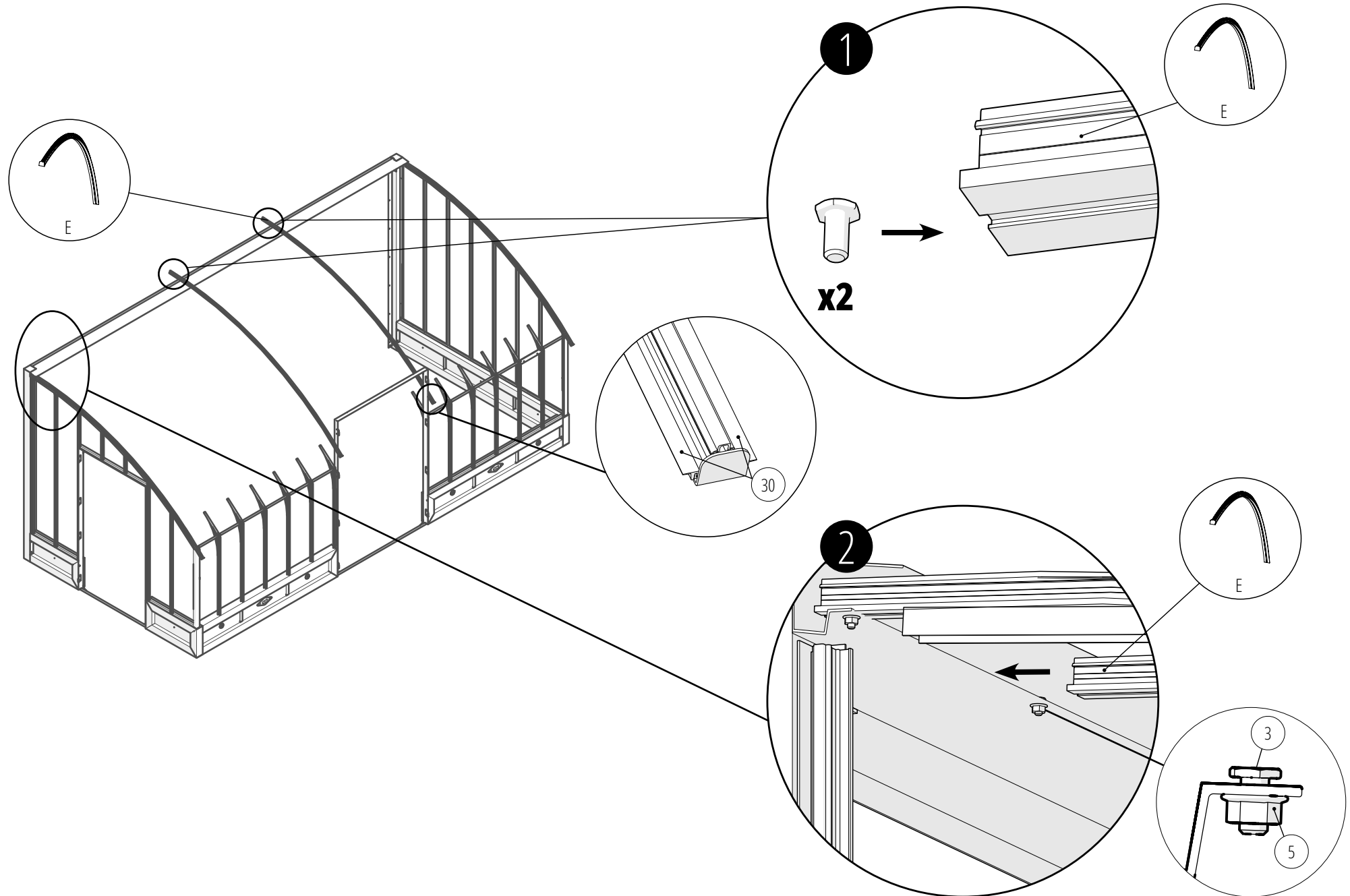



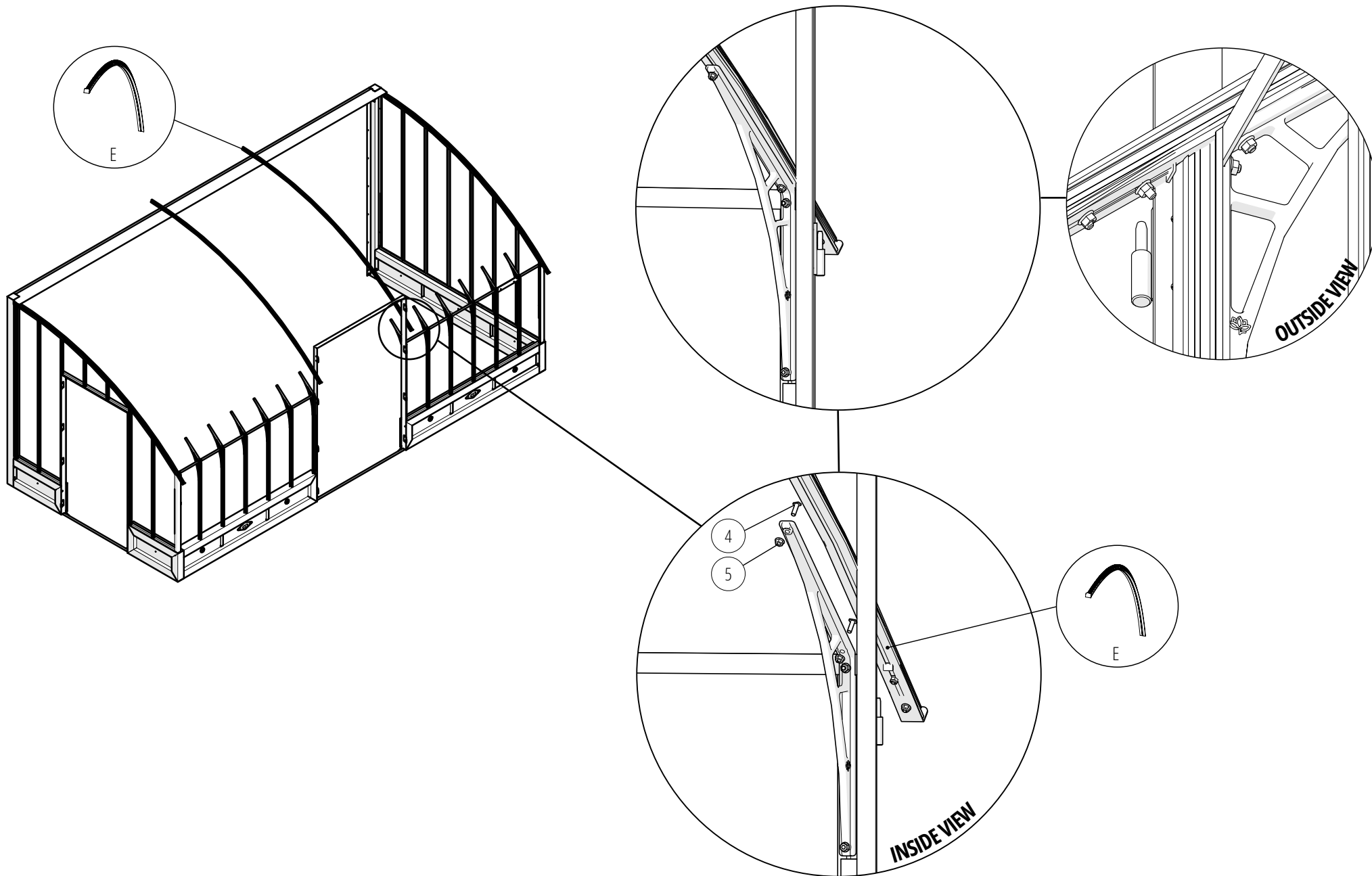







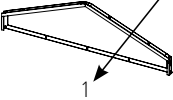



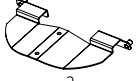









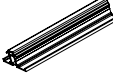

















INSTALLING THE CURVED ROOF PROFILES OF THE DORMER - FIXING THE LOWER PART

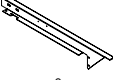

INSTALLING THE DORMER

Part identification

The 6-digit number (example : 606792) allows for reference if you need to reach our customer service.

Part detail	Reference	Part detail	Reference	Part detail	Reference	Part detail	Reference	Part detail	Reference
<i>Dormer triangle - 1469x436x50</i> 	606792	<i>Upper crosspiece - Right side triangle</i> 	606806	<i>Reinforcement - Left side triangle</i> 	606816	<i>Right welded gutter</i> 	606826	<i>Hammer-head screw - M6x12mm</i> 	365401
<i>Dormer ridge plate</i> 	606796	<i>Reinforcement - Right side triangle</i> 	606807	<i>Profile L. 220 mm Left side triangle</i> 	606817	<i>Left welded gutter</i> 	606832	<i>Screw M4,2x16mm</i> 	365426
<i>Right profile L. 152mm</i> 	606798	<i>Coping - Left/Right side triangle</i> 	606808	<i>Profile L. 470 mm Left side triangle</i> 	606818	<i>Profile + bracket L. 915mm</i> 	606841	<i>Black plastic cover cap - M6</i> 	365483
<i>Left profile L. 152mm</i> 	606799	<i>Profile L. 220 mm Right side triangle</i> 	606809	<i>Profile L. 776 mm Left side triangle</i> 	606819	<i>Profile + bracket L. 550mm</i> 	606843	<i>Nut M6</i> 	789280
<i>Right profile L. 300mm</i> 	606800	<i>Profile L. 470 mm Right side triangle</i> 	606810	<i>Dormer ridge L. 3134mm</i> 	606820	<i>Profile + bracket L. 300mm</i> 	606845	<i>H-head screw M6x20mm</i> 	789300
<i>Left profile L. 300mm</i> 	606801	<i>Profile L. 776 mm Right side triangle</i> 	606811	<i>Side crosspiece L. 1537mm - Right</i> 	606822	<i>Curved profile + bracket L. 920mm</i> 	606847	<i>H-head screw M6x12mm</i> 	994778
<i>Middle profile L. 423mm</i> 	606802	<i>Curved bracket 30x30x2mm - Left side triangle</i> 	606813	<i>Side corsspiece L. 1537mm - Left</i> 	606823	<i>LAMS ridge cover</i> 	605146	<i>Self-taping countersunk screw 6,3x25</i> 	367428
<i>Curved bracket 30x30x2mm - Right side triangle</i> 	606804	<i>Pillar - Left side triangle</i> 	606814	<i>Right ridge sheet</i> 	606824	<i>Screw M5x12</i> 	364409	<i>Countersunk screw M6x20</i> 	365418
<i>Pillar - Right side triangle</i> 	606805	<i>Upper crosspiece - Left side triangle</i> 	606815	<i>Left ridge sheet</i> 	606825	<i>Nut M5</i> 	364410	<i>Seal for the dormer ridge</i> 	607829

INSTALLING THE DORMER

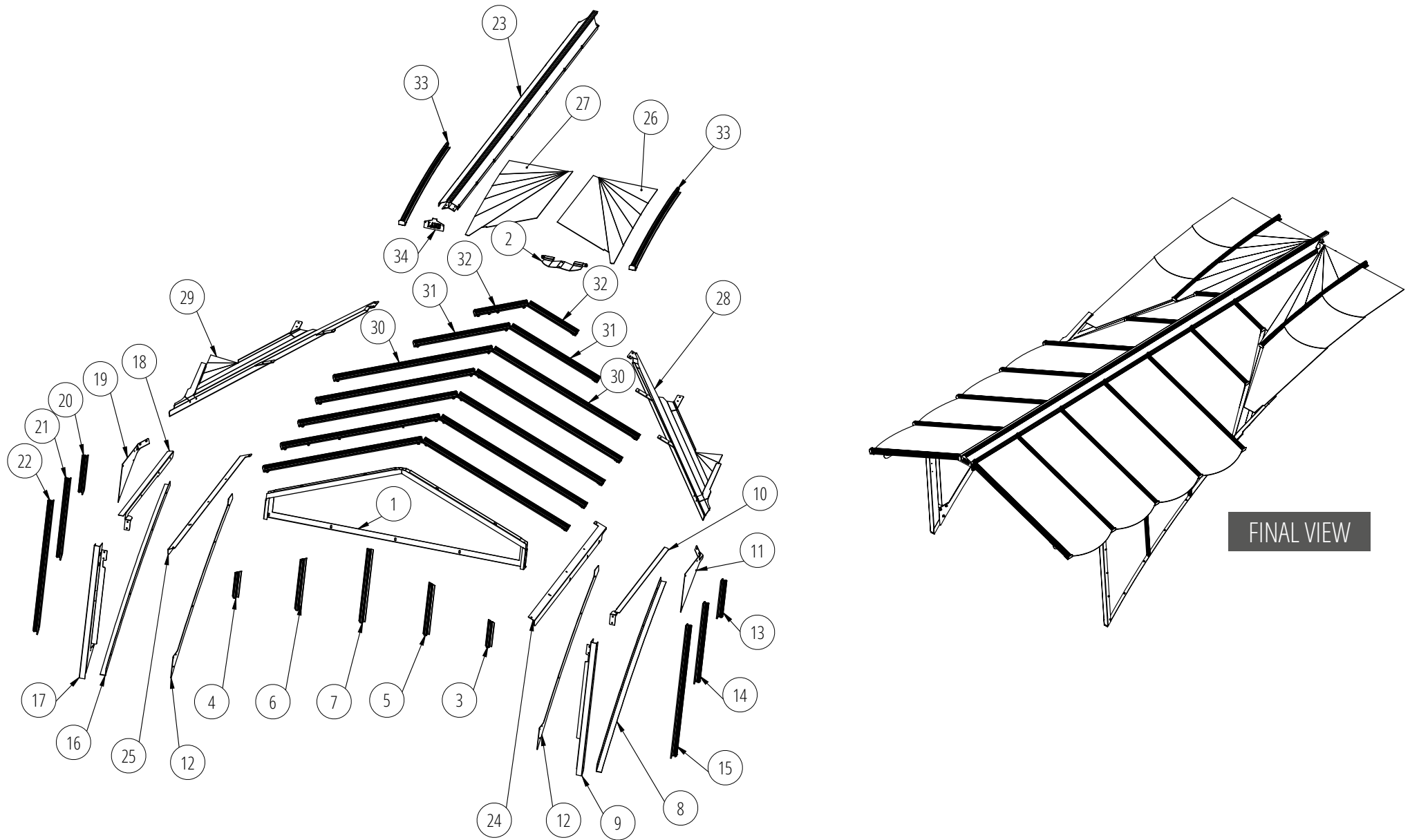

ASSEMBLING THE SIDE TRIANGLES OF THE DORMER

On the following pages, you will find the steps to assemble the right side triangle of the dormer (right side when facing the glasshouse). You will need to repeat these steps for the left side triangle, the principle remains the same. **Please note that the profiles for the right and left side may vary, so refer to the indicated part number.**

Right side triangle: Please note that the tab of n°10 slides behind n°9

Left side triangles: Please note that the tab of n°18 slides behind n°17

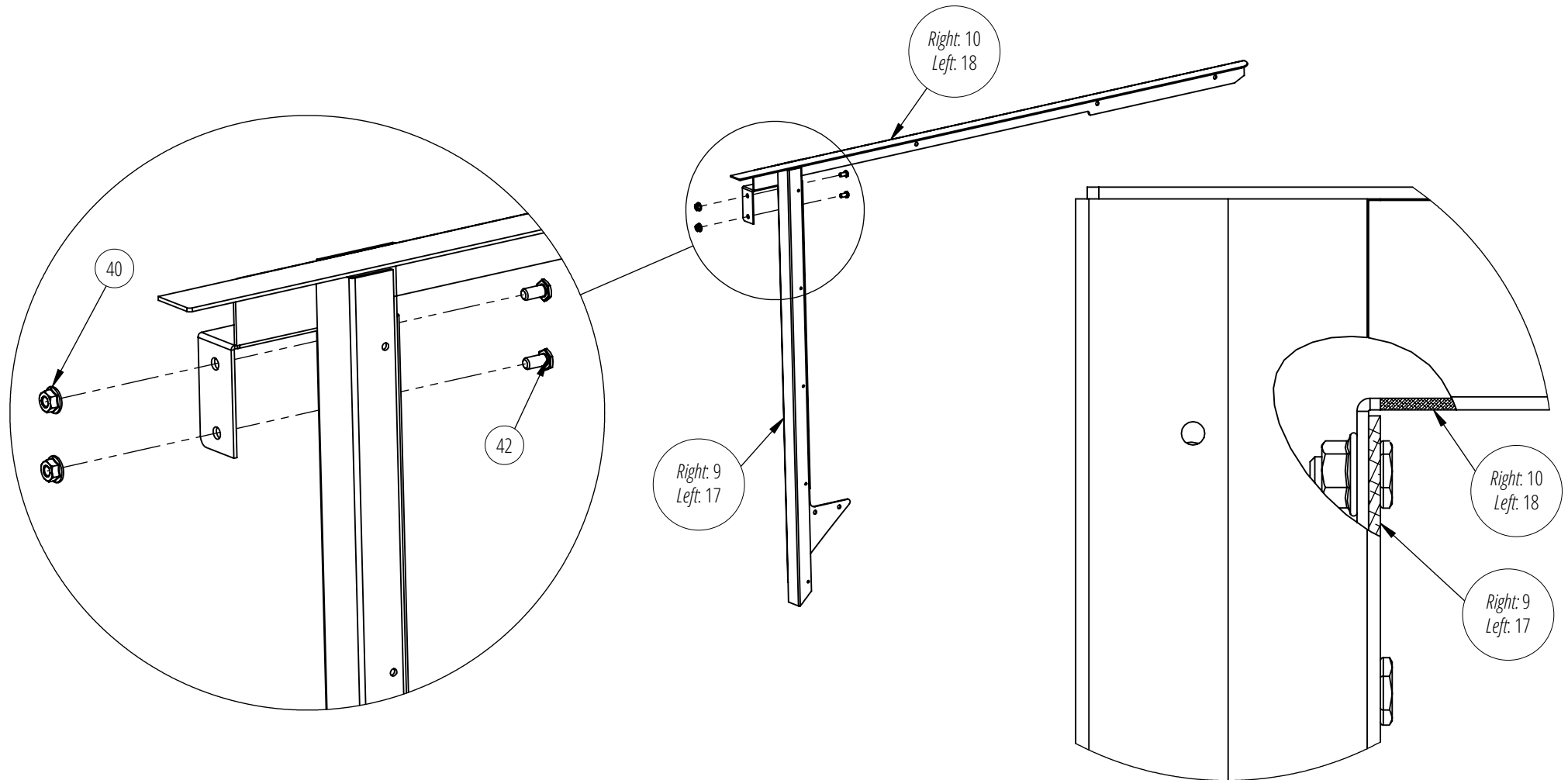

ASSEMBLING THE SIDE TRIANGLES OF THE DORMER

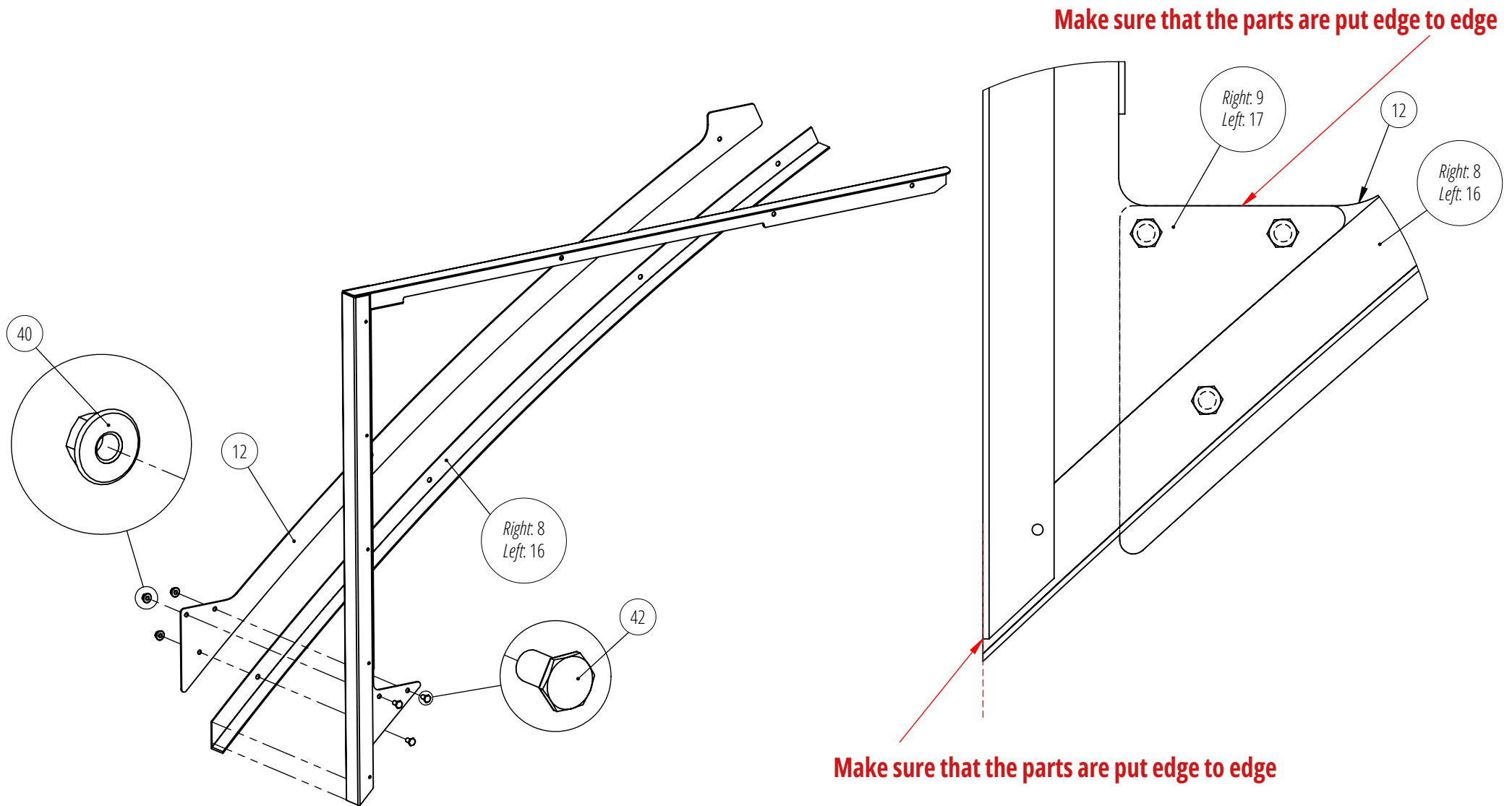

ASSEMBLING THE SIDE TRIANGLES OF THE DORMER

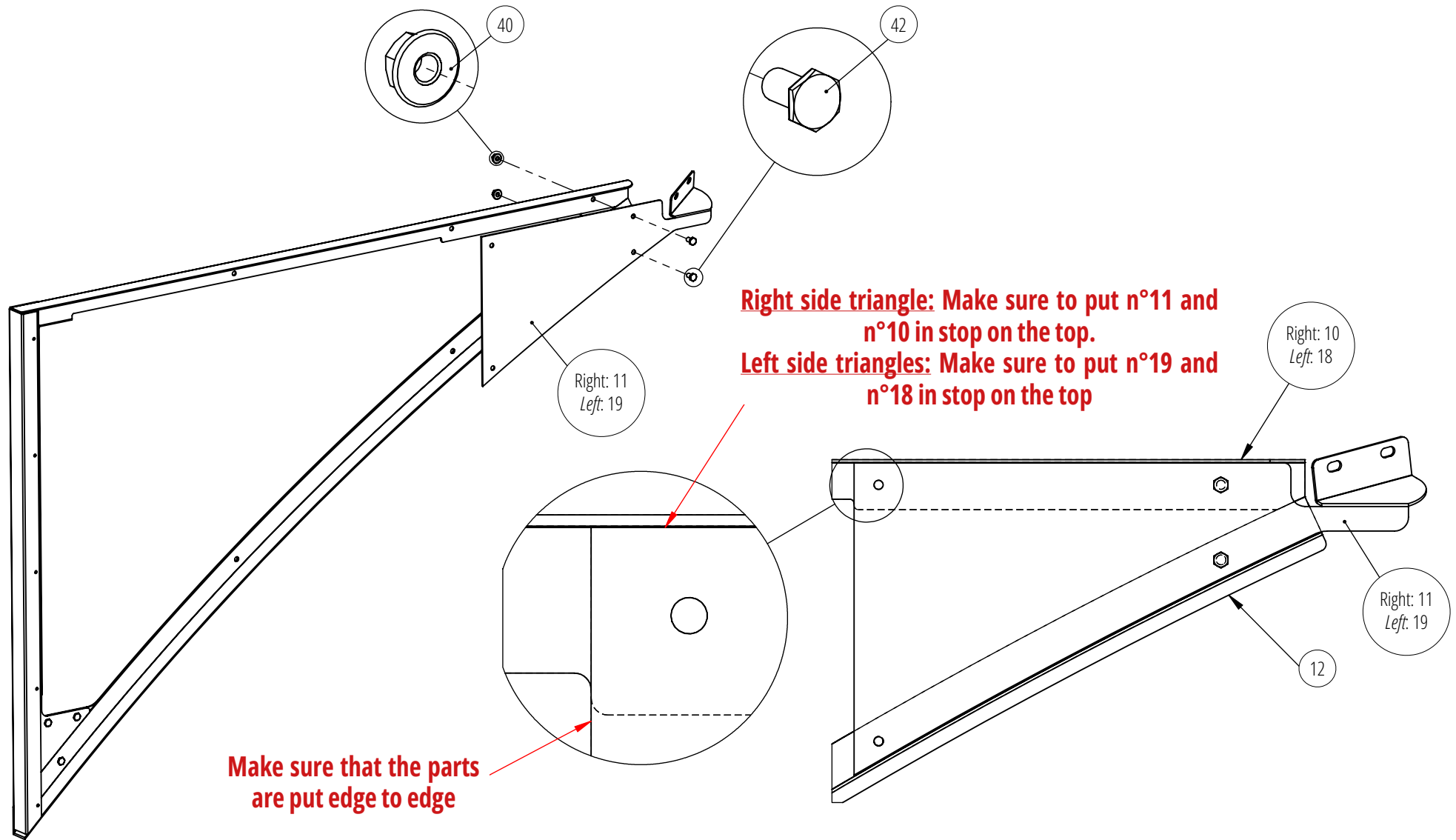

ASSEMBLING THE SIDE TRIANGLES OF THE DORMER

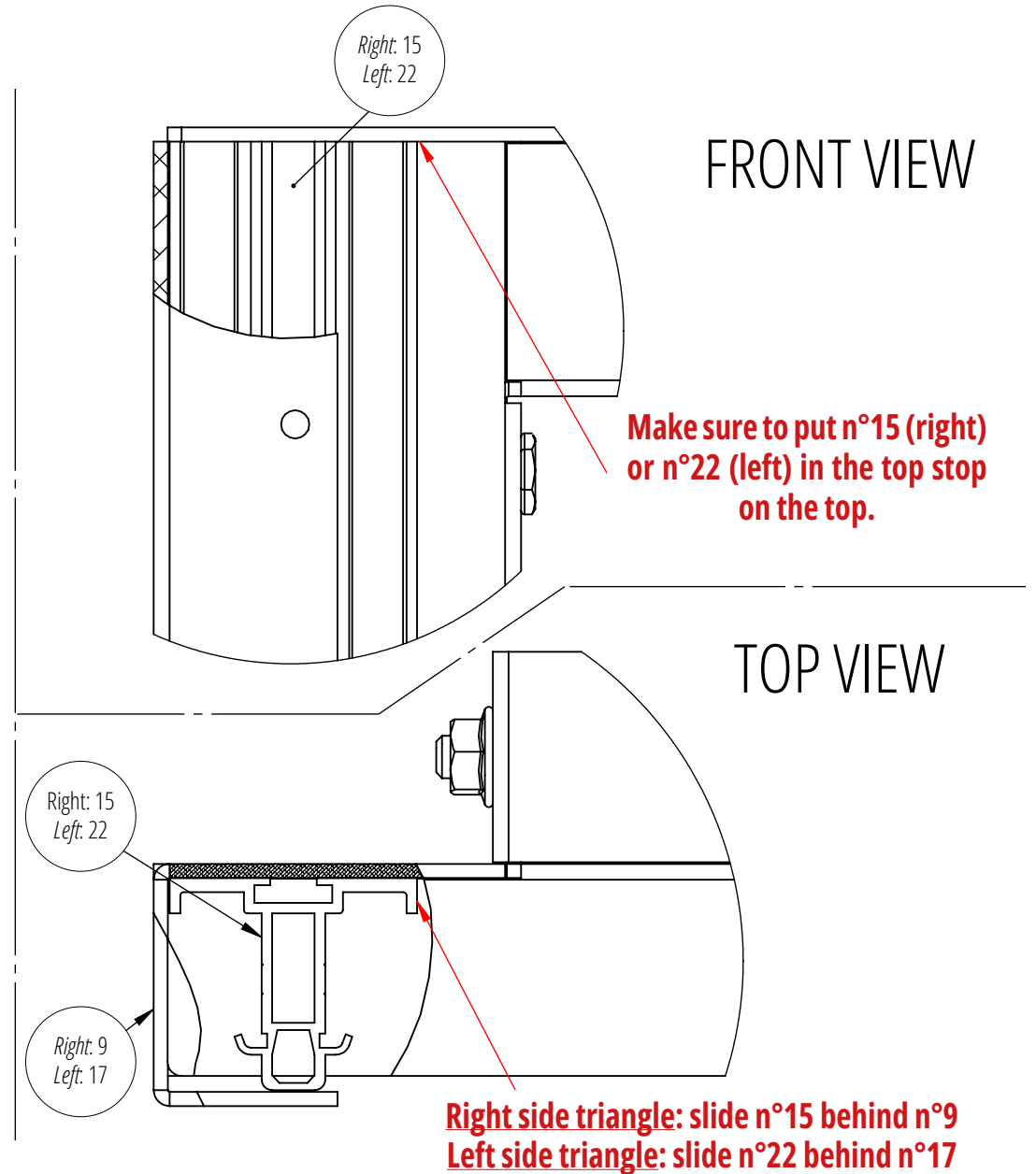
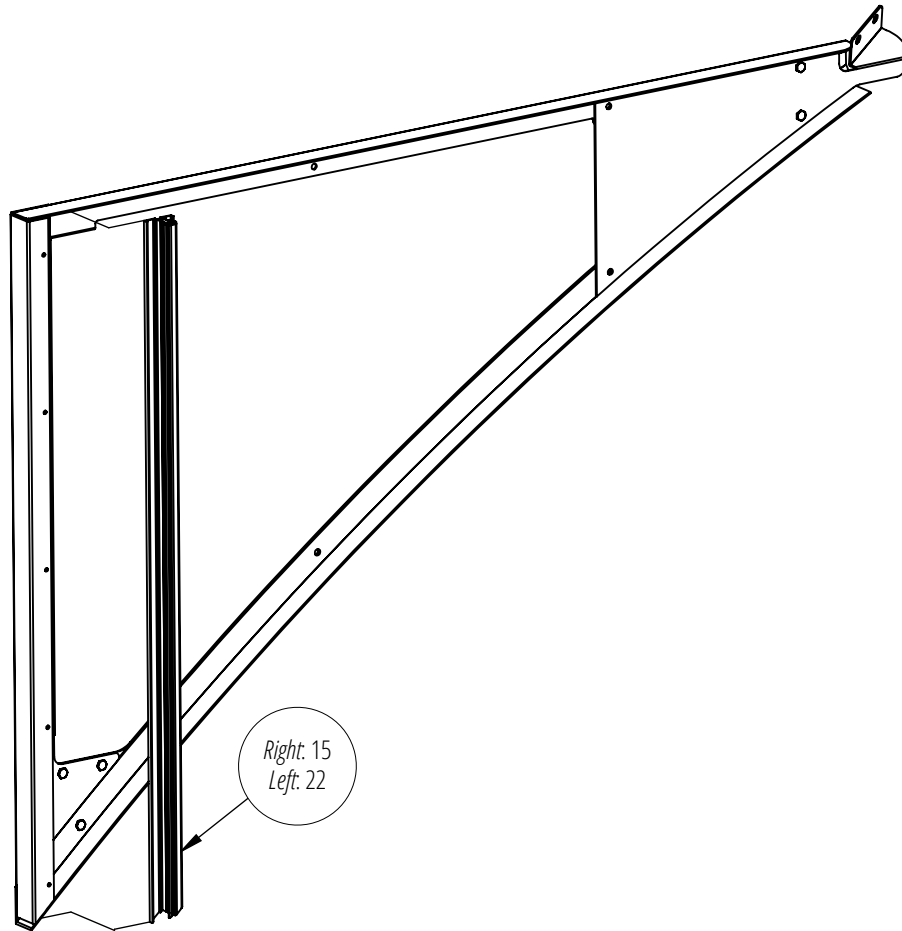

ASSEMBLING THE SIDE TRIANGLES OF THE DORMER

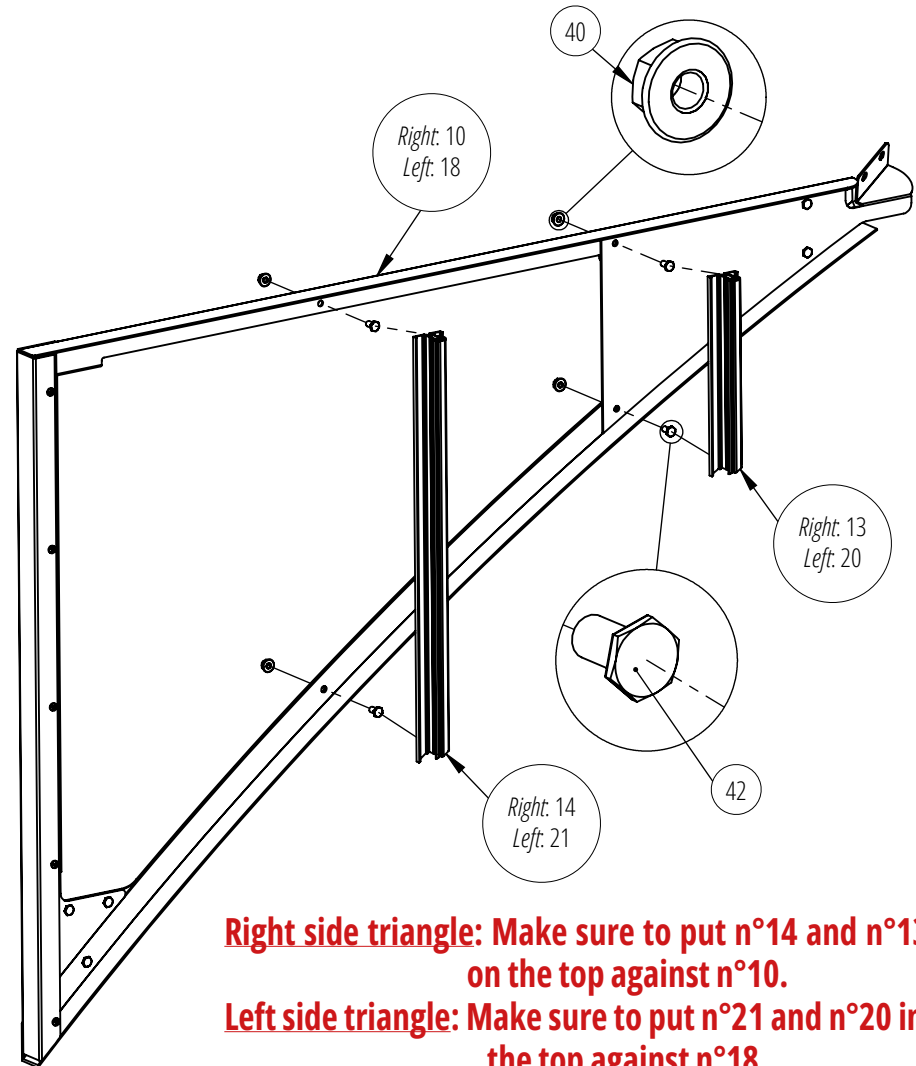
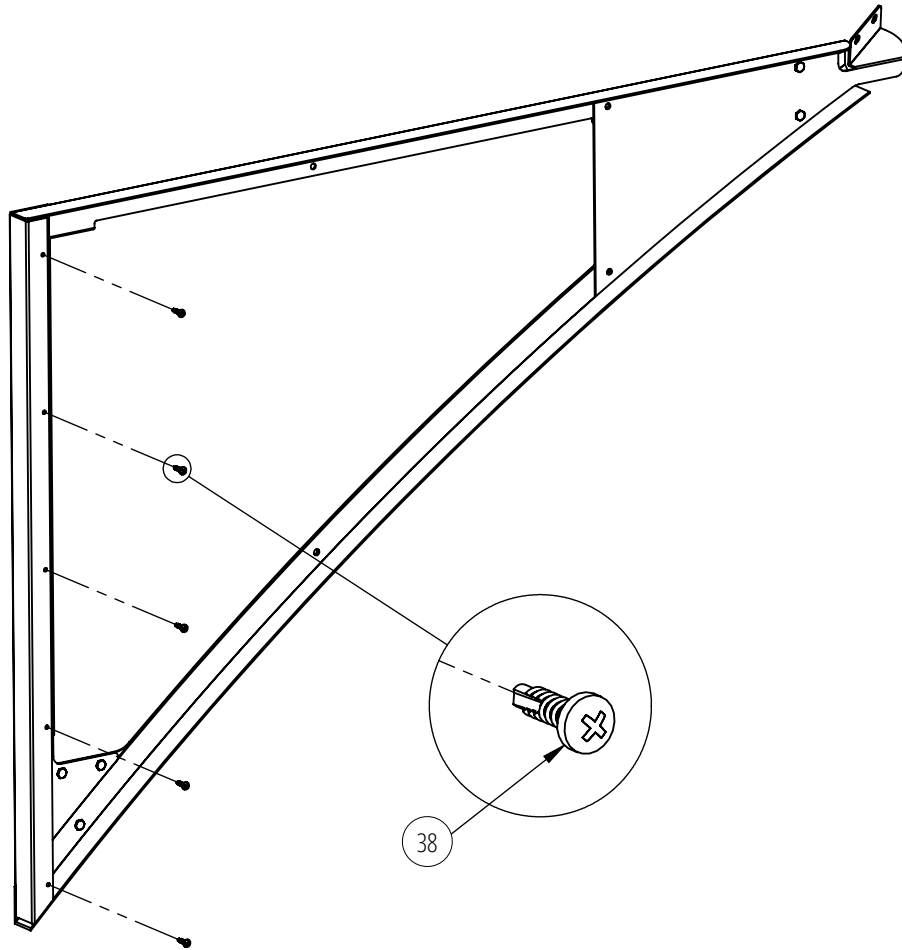

Right side triangle: Make sure to put n°14 and n°13 in stop on the top against n°10.

Left side triangle: Make sure to put n°21 and n°20 in stop on the top against n°18.

Do not fully tighten the top bolts.

ASSEMBLING THE SIDE TRIANGLES OF THE DORMER

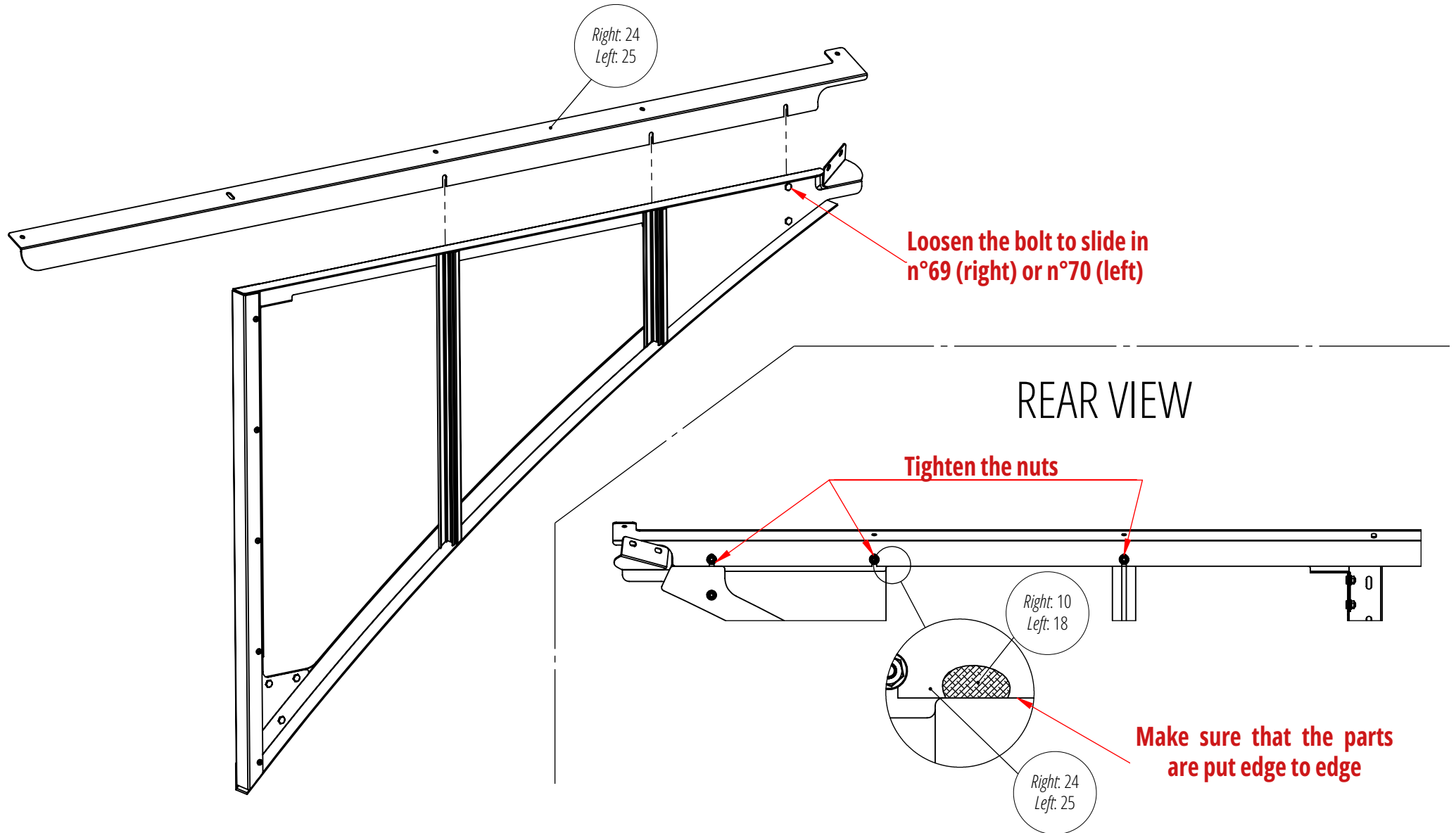

As a reminder, you should fit your left side triangle in the same way as your right side triangle.

INSTALLATION OF THE DORMER

Once you have your 2 side triangles, you can mount the dormer.

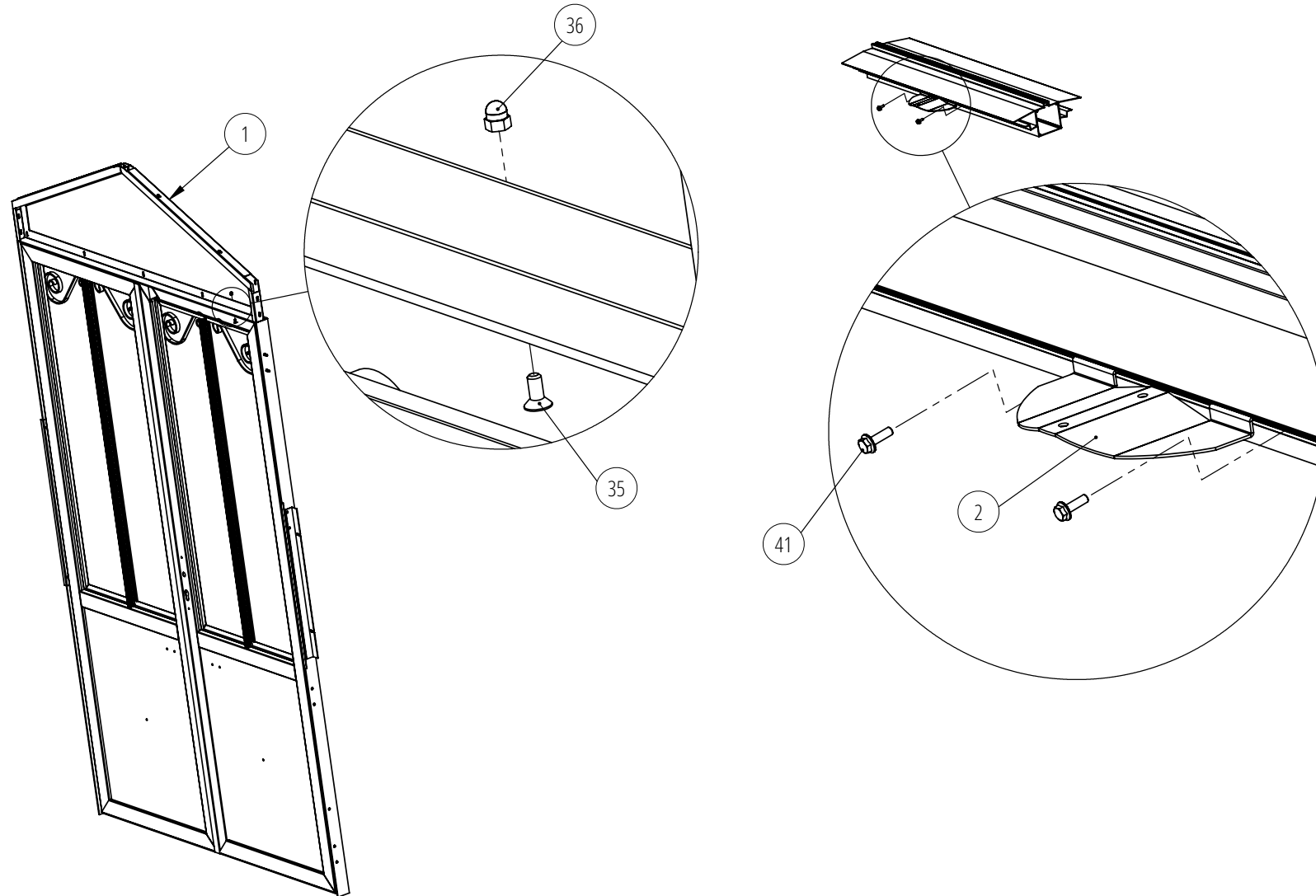

INSTALLATION OF THE DORMER

Before installing the triangles, be careful to put the seal on the curved roof profiles of the glasshouse until they touch the door frame.

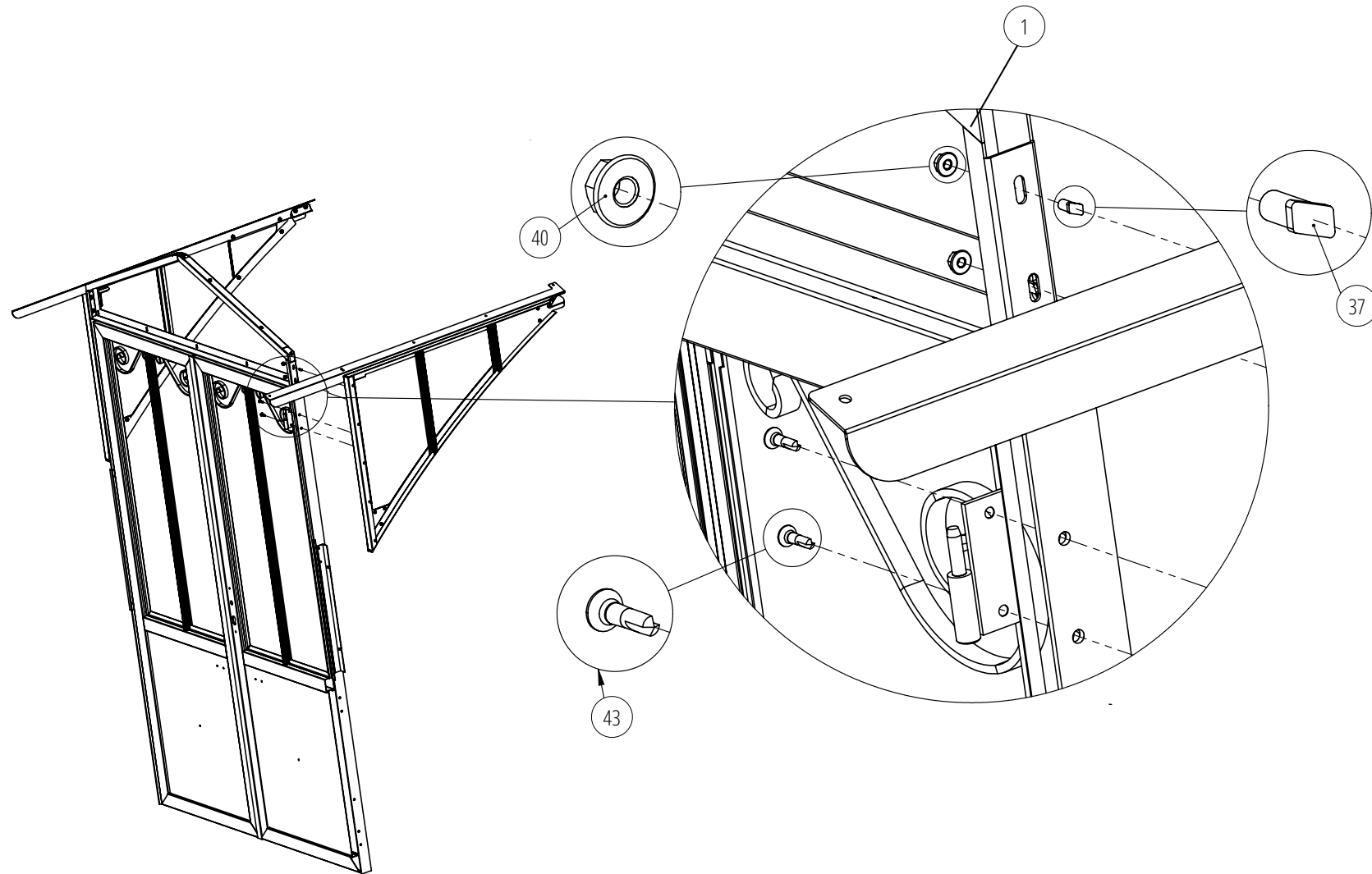

INSTALLATION OF THE DORMER

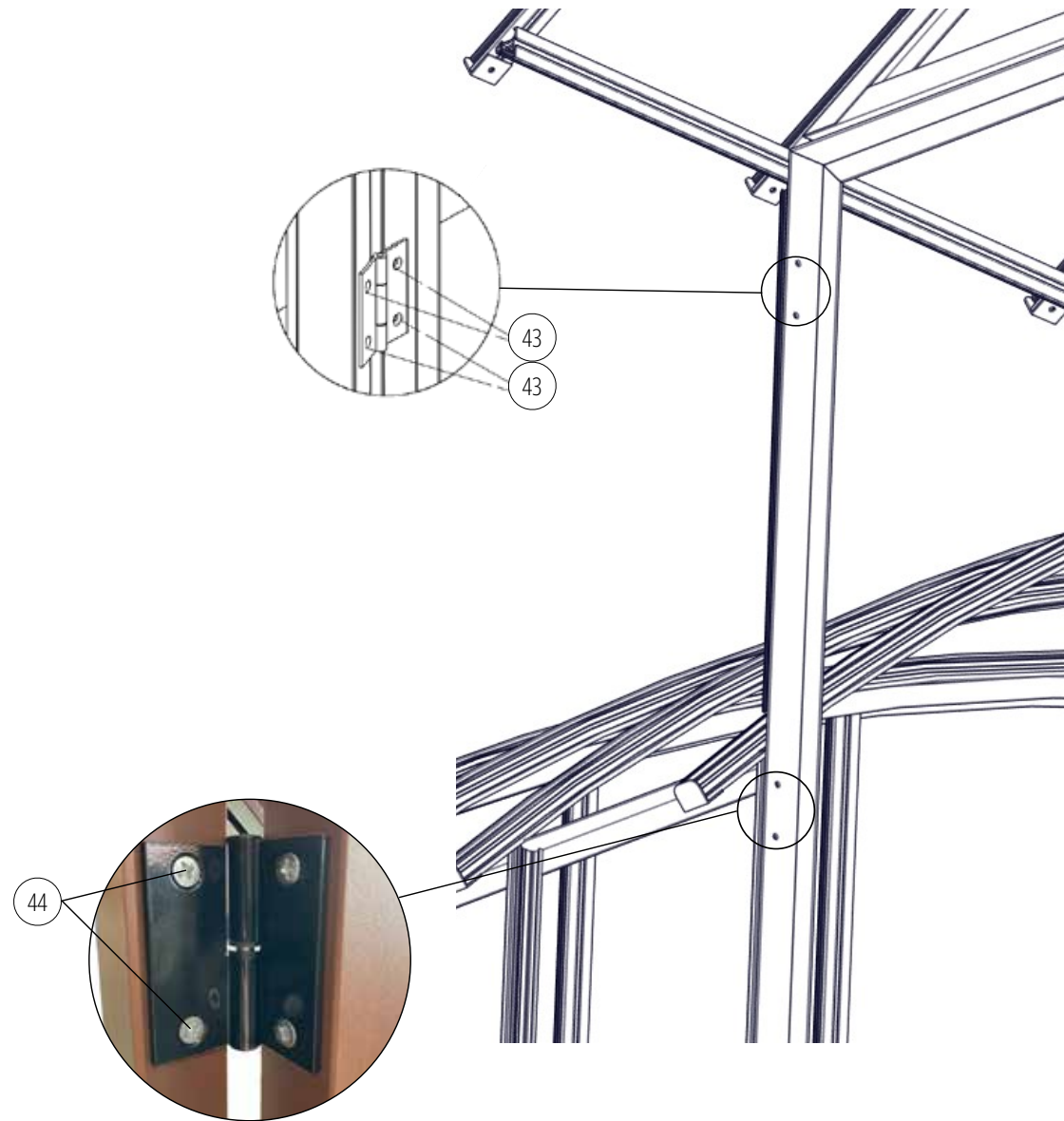

INSTALLATION OF THE DORMER

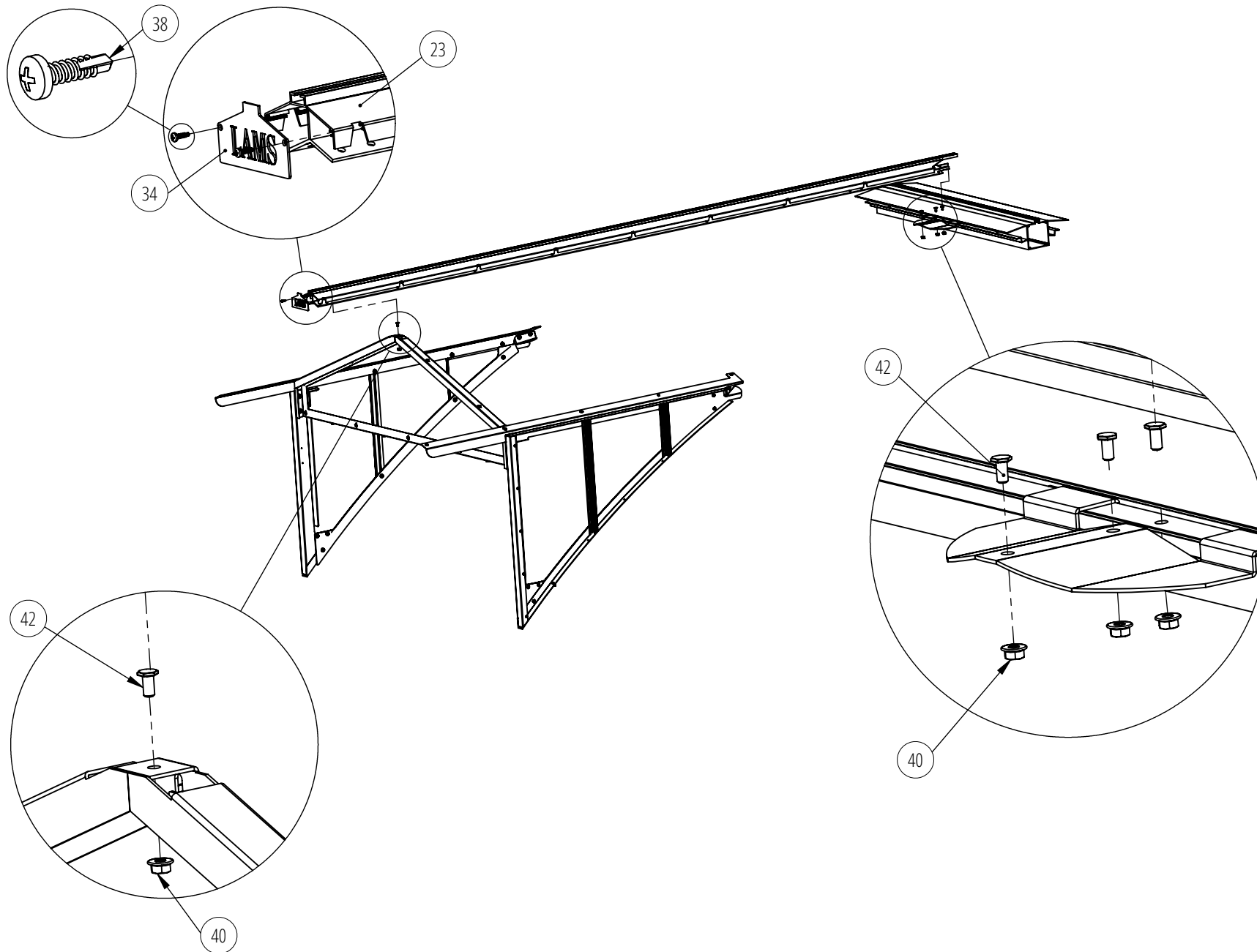

INSTALLATION OF THE DORMER

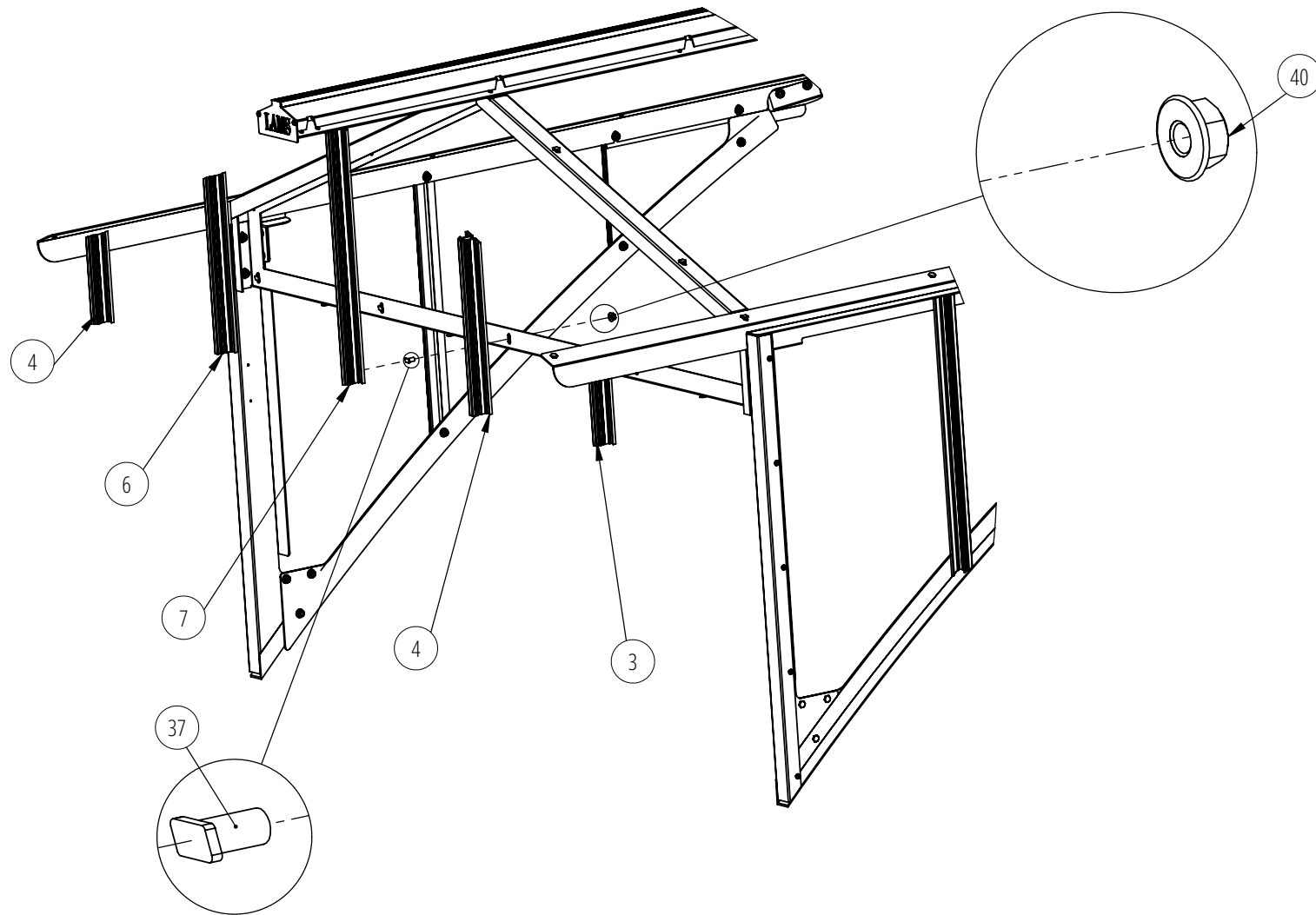

INSTALLATION OF THE DORMER

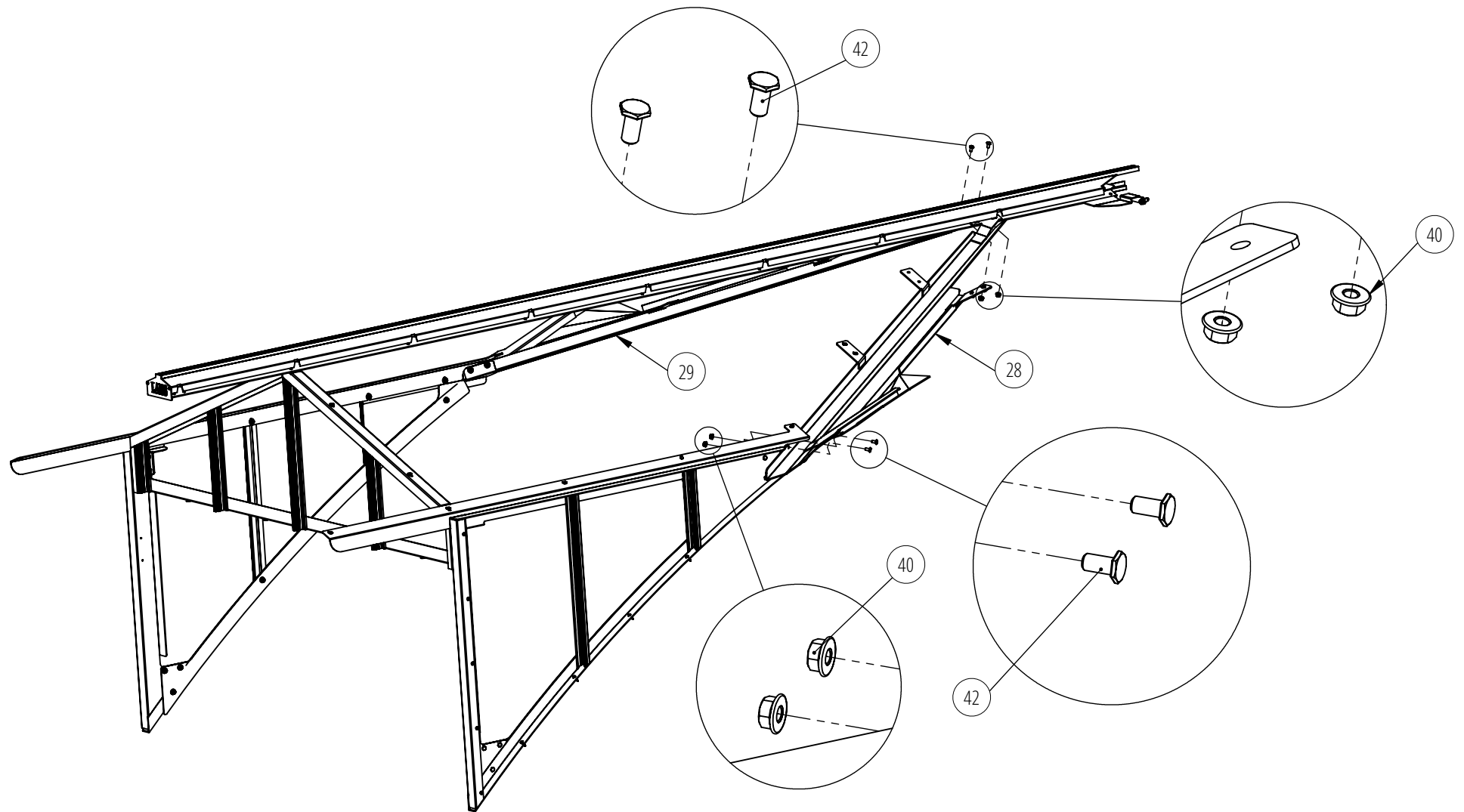

INSTALLATION OF THE DORMER

Note that the profiles (30) on the front triangle (1) are secured with three hammerhead screws (37) and one hex-head screw (42).
The other with one hex-head screw (42) and one hammerhead screw (37).

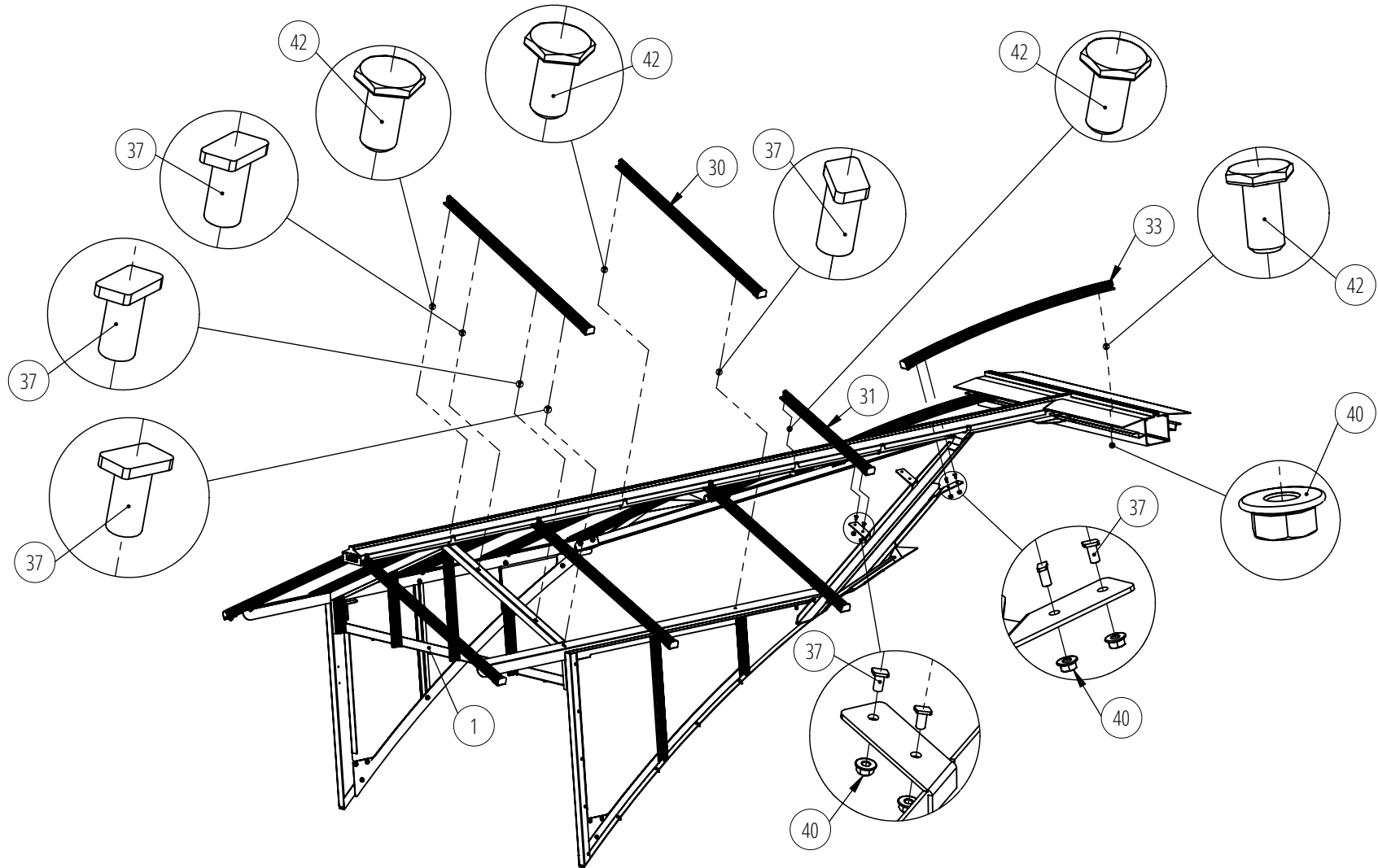

INSTALLING THE SEAL ON THE DORMER

For optimal sealing, especially if your glasshouse is exposed to the wind, you can install the gasket (45) between the glass and the ridge.
Cut the gasket into 12 pieces of 355mm and 2 pieces of 700mm.

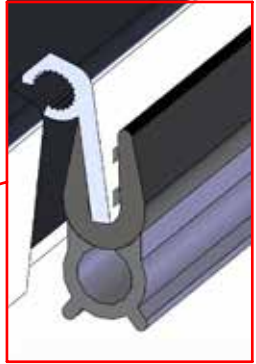
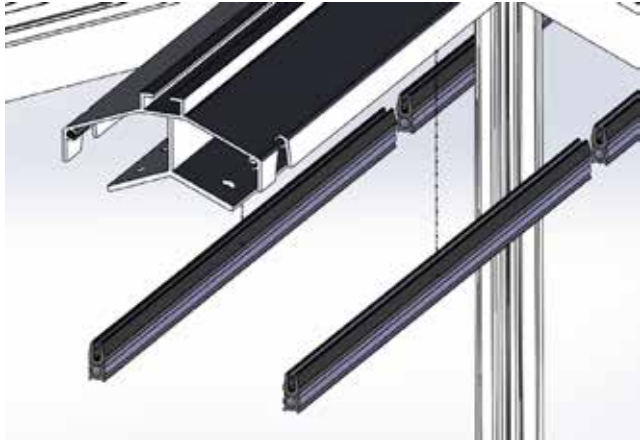
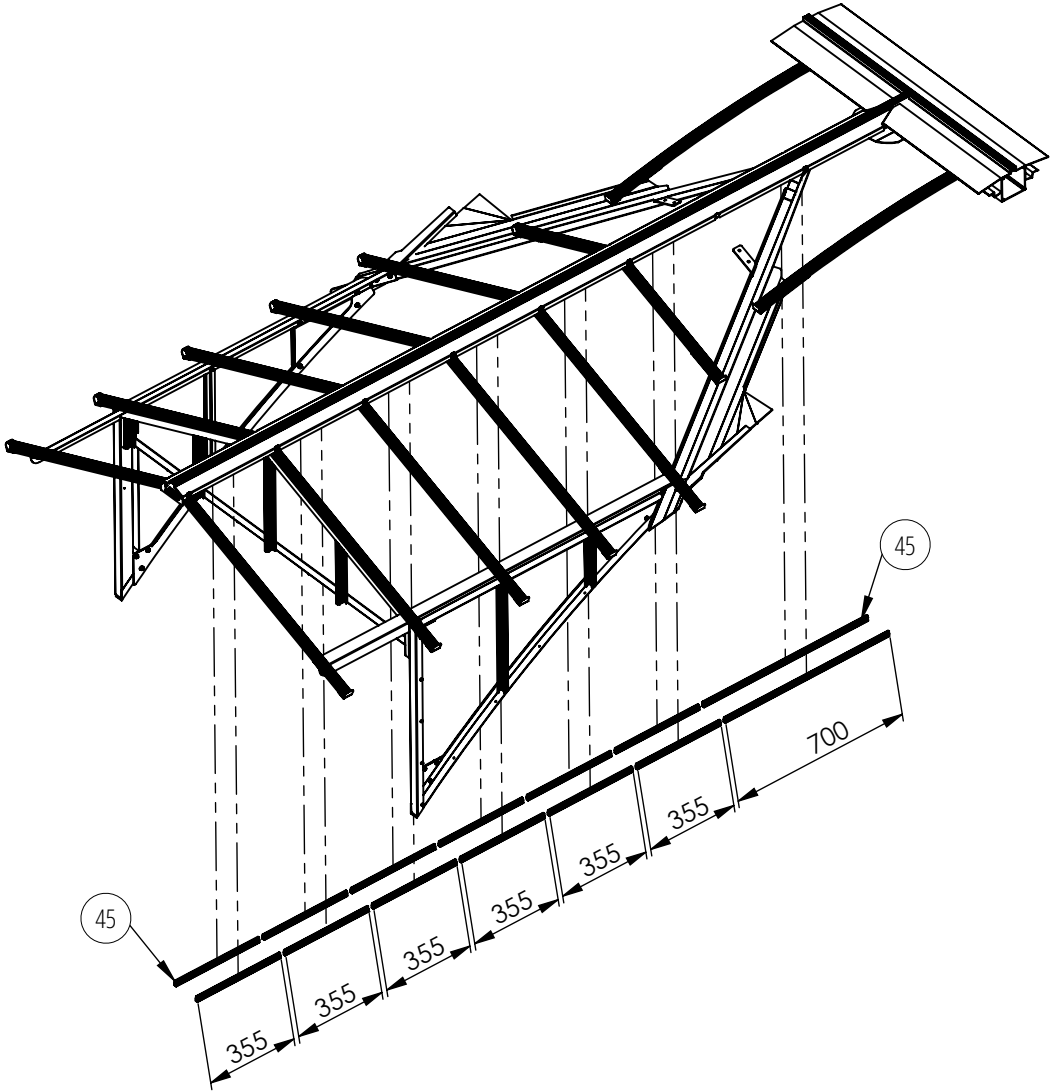

INSTALLATION OF THE DORMER

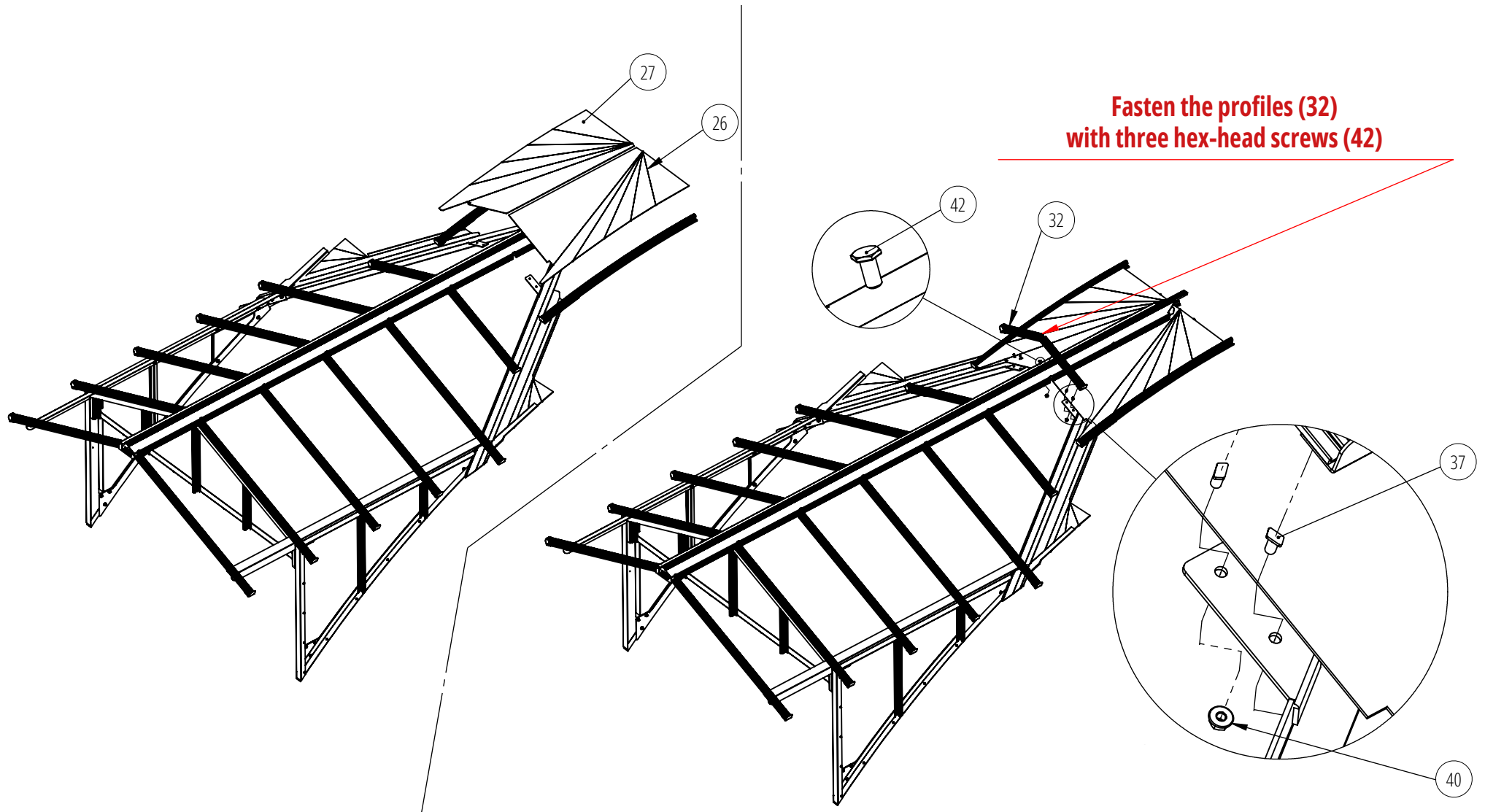

INSTALLATION OF THE DORMER

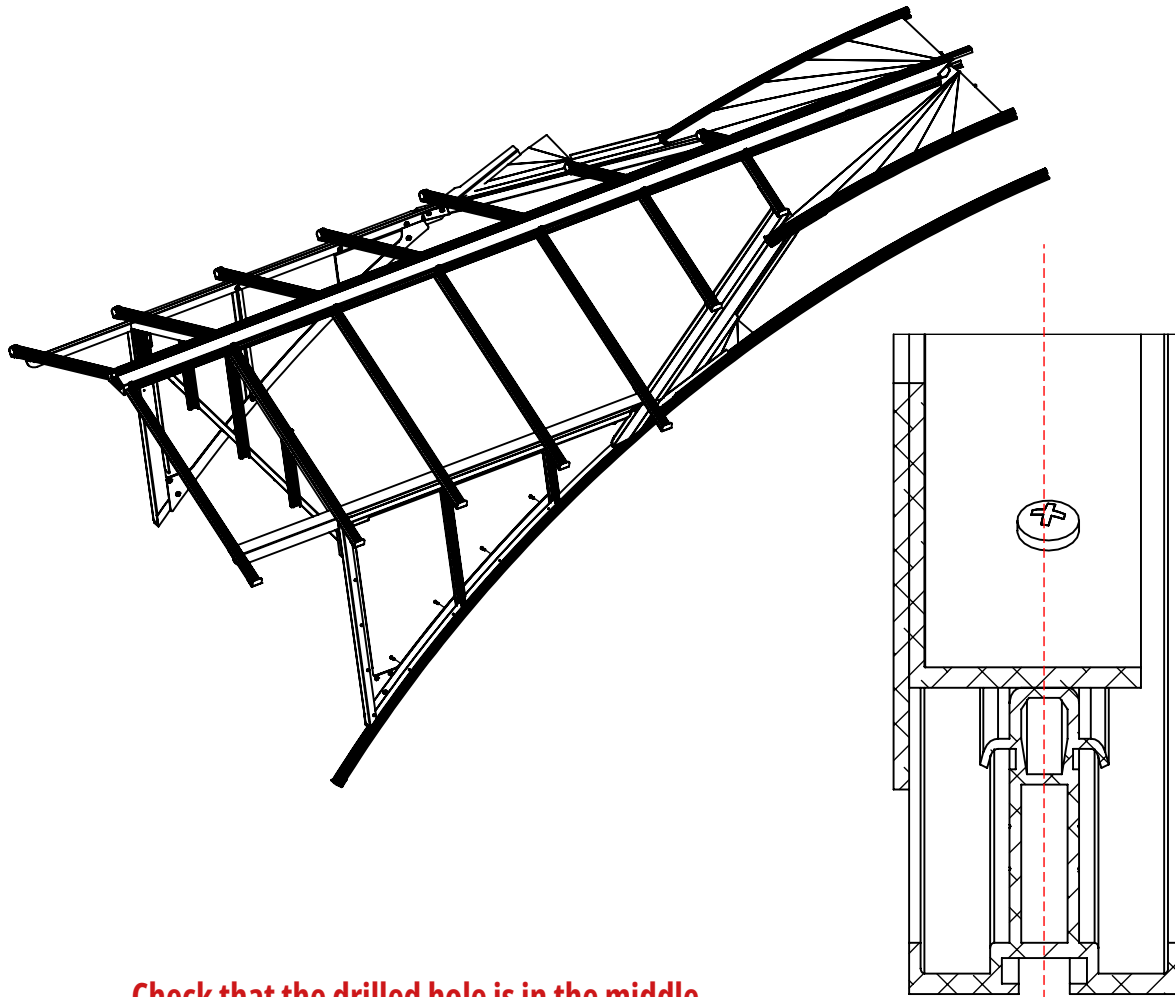

Check that the drilled hole is in the middle of the curved profile before tightening

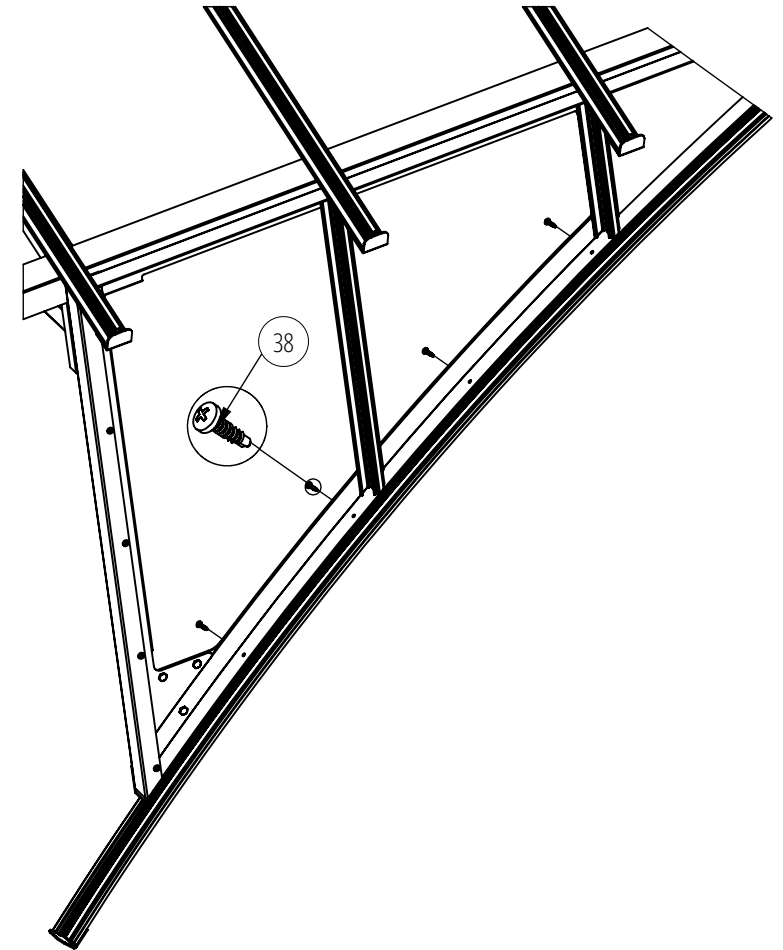

INSTALLATION OF THE DORMER

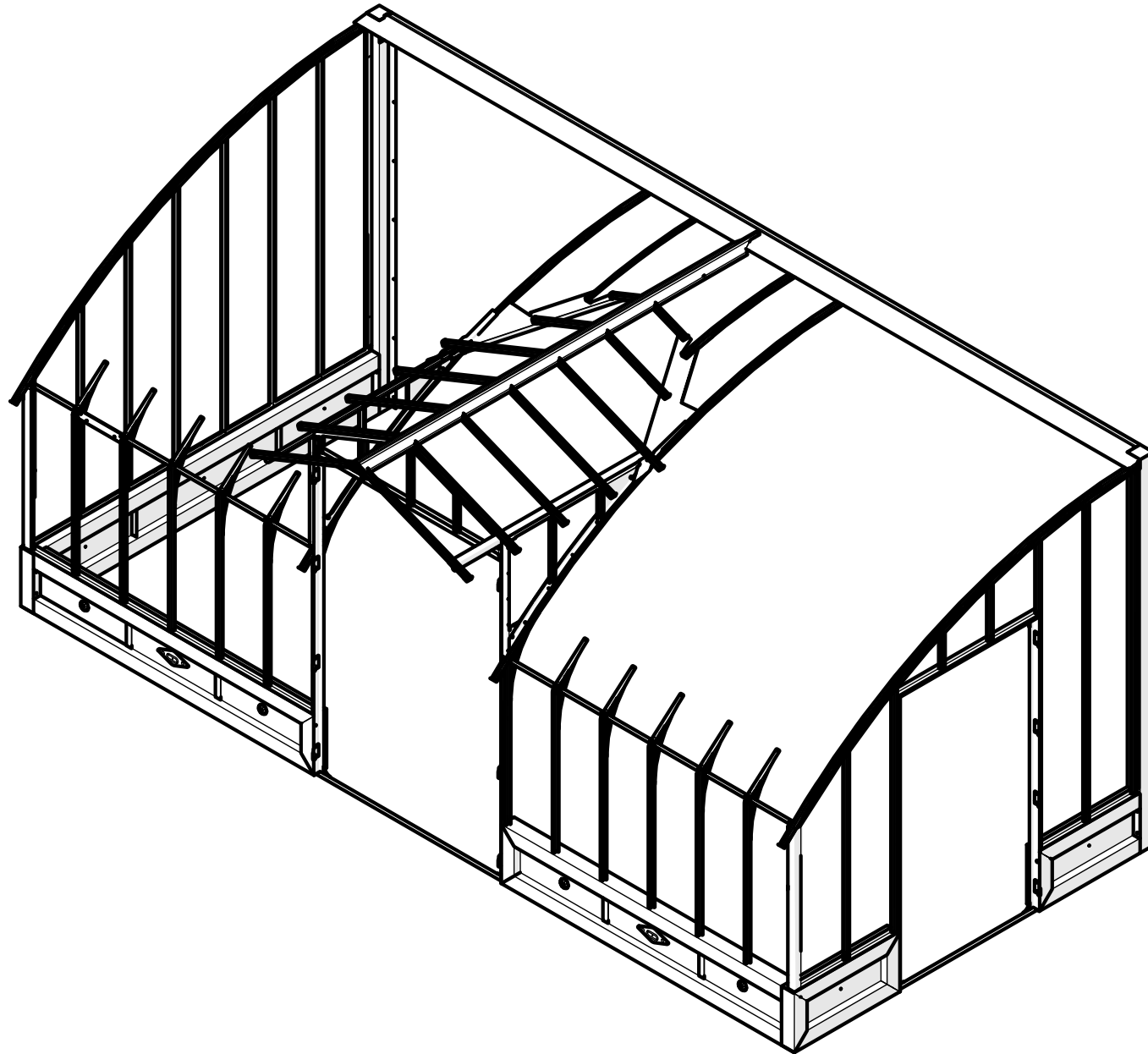

INSTALLING THE CURVED ROOF PROFILES - FIXING THE UPPER PART

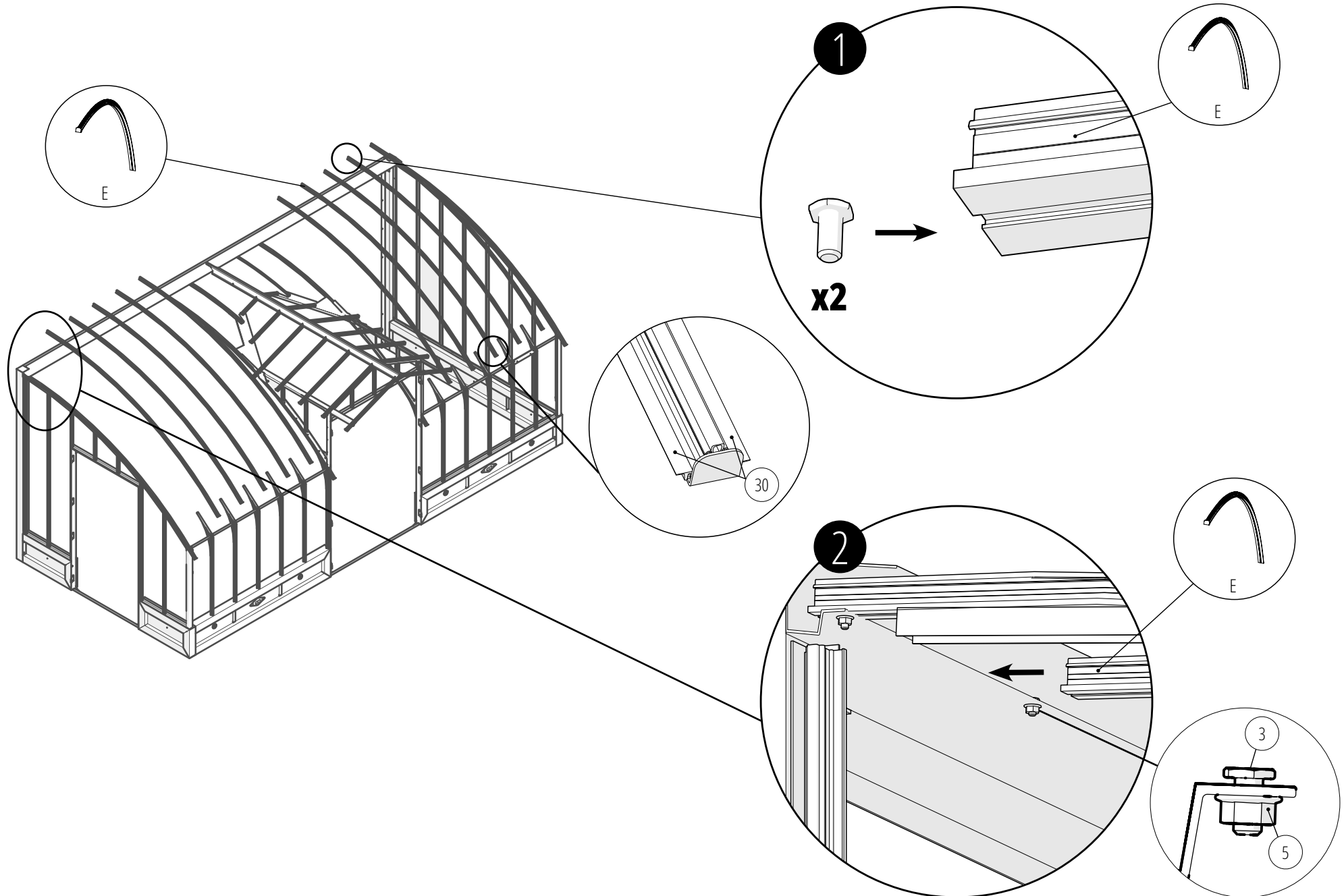

INSTALLING THE CURVED ROOF PROFILES - FIXING THE LOWER PART

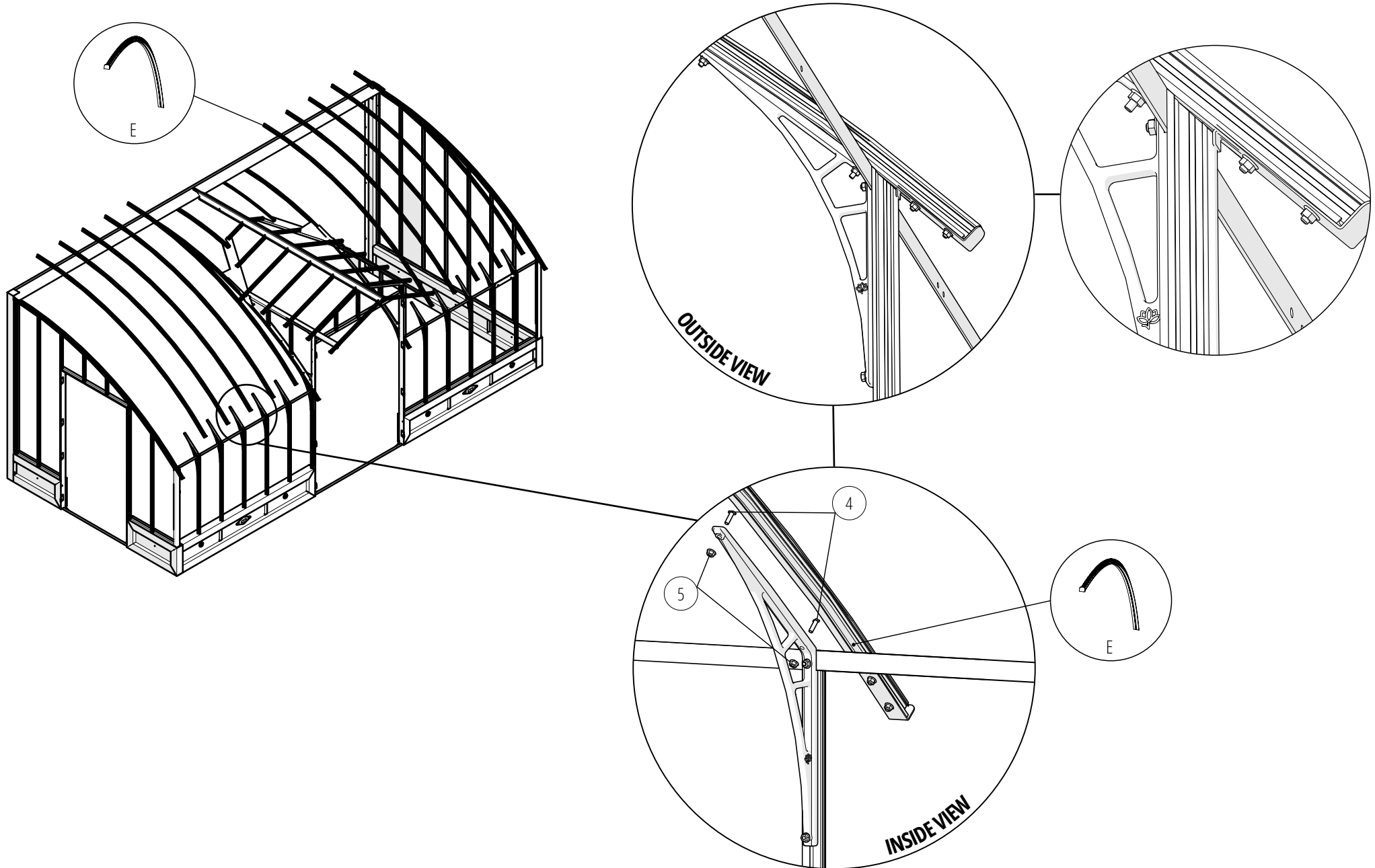

INSTALLING THE ROOF BEAMS

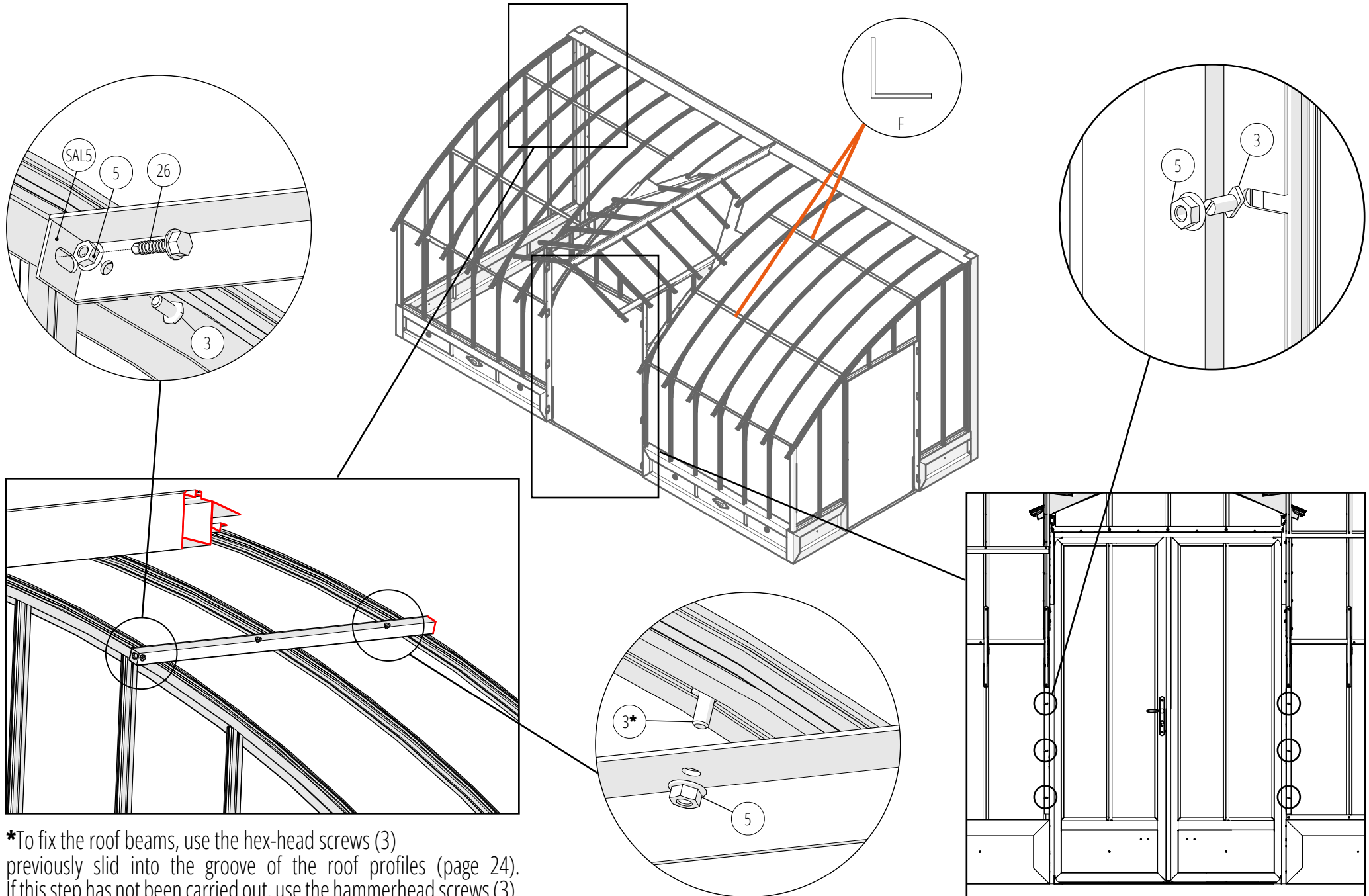

*To fix the roof beams, use the hex-head screws (3) previously slid into the groove of the roof profiles (page 24). If this step has not been carried out, use the hammerhead screws (3).

INSTALLING THE DOOR AND ROOF WINDOWS

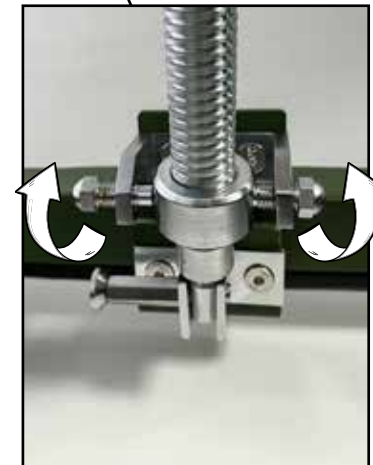
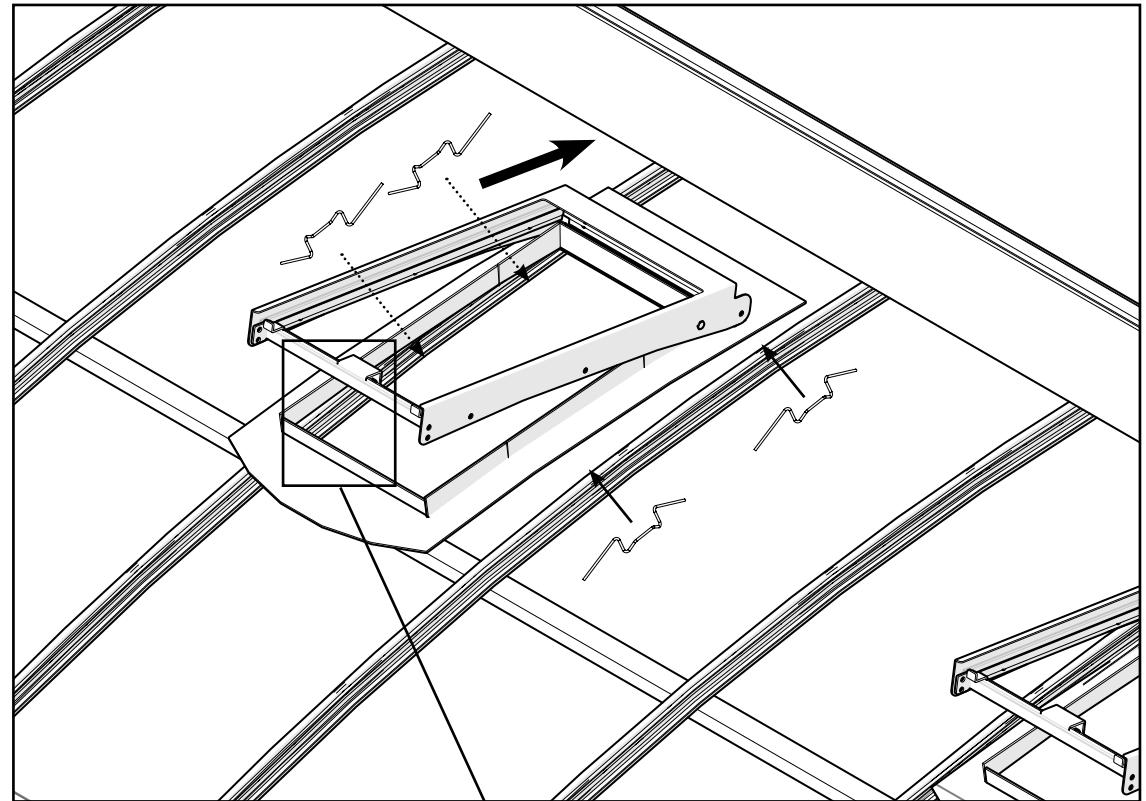
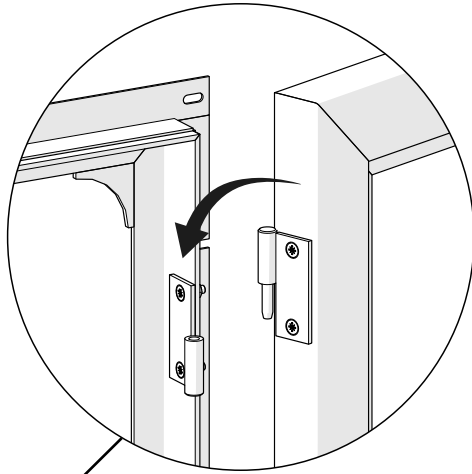

INSTALLING THE WALL WINDOWS

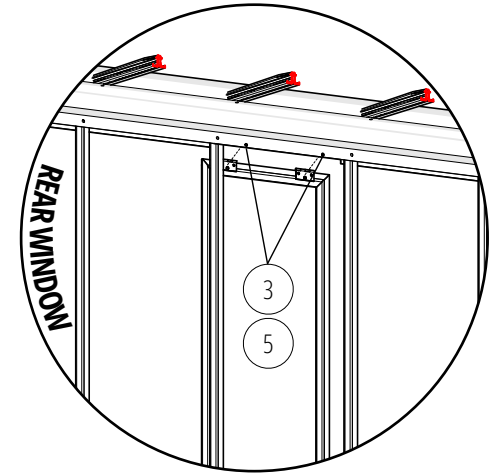
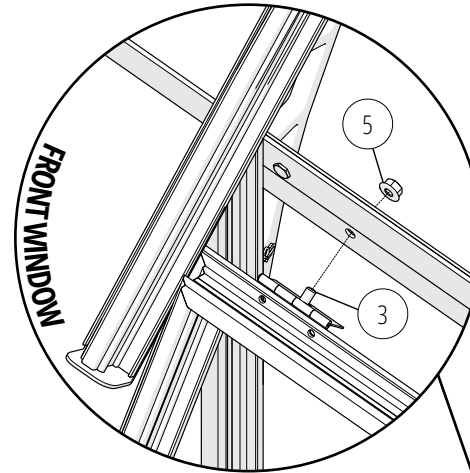
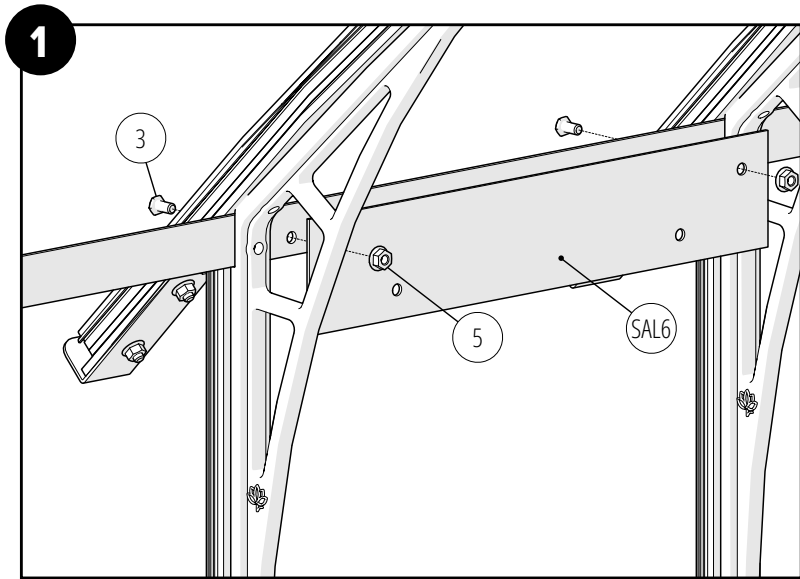

3 With a base height of 40 cm and/or a ridge height of 3.10 m, a window stopper profile (P) should be positioned as follows:

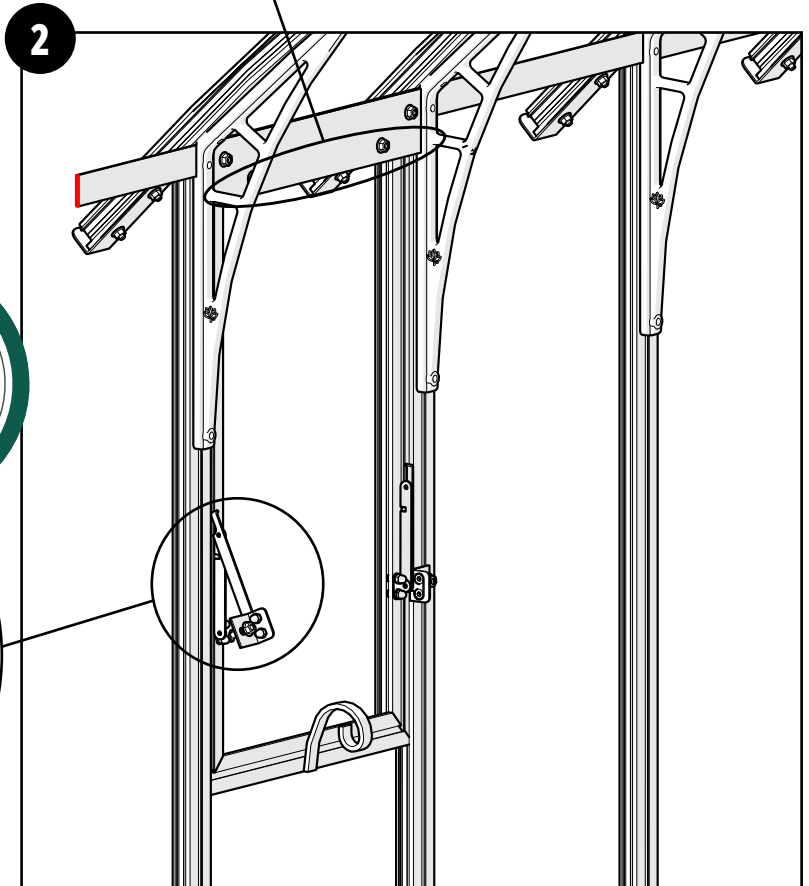
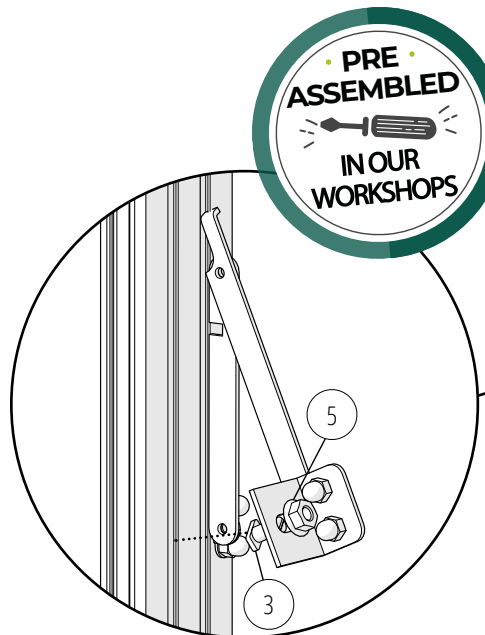
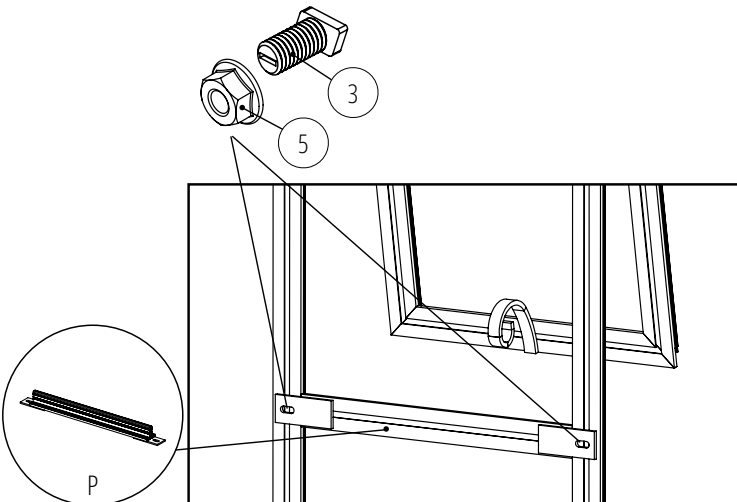

INSTALLING THE WALL AND ROOF GLAZING - RIDGE HEIGHT 2.70 M

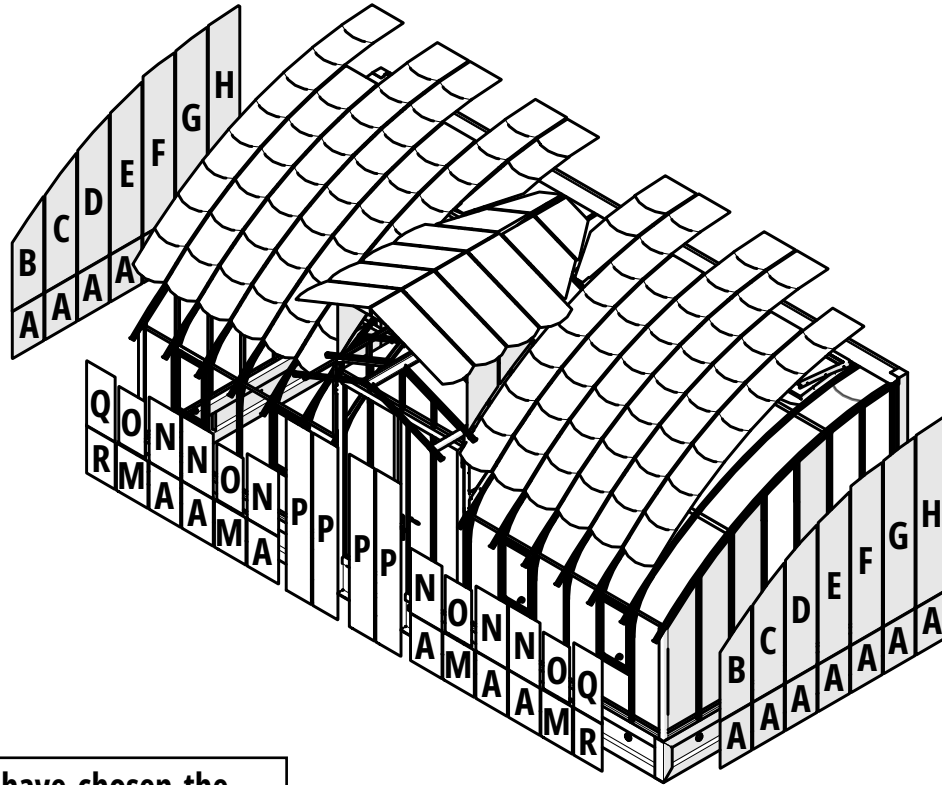

Letter	Base H. 40 cm		Base H. 87 cm	
	Size (in mm)	Number of clips	Size (in mm)	Number of clips
A	482 x 358	4	/	/
B	960 x 358	4	960 x 358	4
C	1200 x 358	4	1200 x 358	4
D	1390 x 358	4	1390 x 358	4
E	1530 x 358	4	1530 x 358	4
F	1635 x 358	6	1635 x 358	6
G	1700 x 358	6	1700 x 358	6
H	1735 x 358	6	1735 x 358	6
I	1685 x 262	6	1685 x 262	6
J	1685 x 358	6	1685 x 358	6
K	985 x 300	6	985 x 300	6
L	625 x 358	6	625 x 358	6
M	465 x 358	2	/	/
N	645 x 358	4	645 x 358	4
O	557 x 300	4	557 x 300	4
P	1710 x 285	6	1240 x 285	6
Q	645 x 324	4	645 x 324	4
R	482 x 324	2	/	/
S	482 x 262	2	/	/
T	266 x 358	2	266 x 358	2
U	410 x 358	2	410 x 358	2
V	510 x 358	2	510 x 358	2
W	1531 x 304	6	1053 x 304	6
Z	400 x 358	2	400 x 358	2

If you have chosen the optional side door:

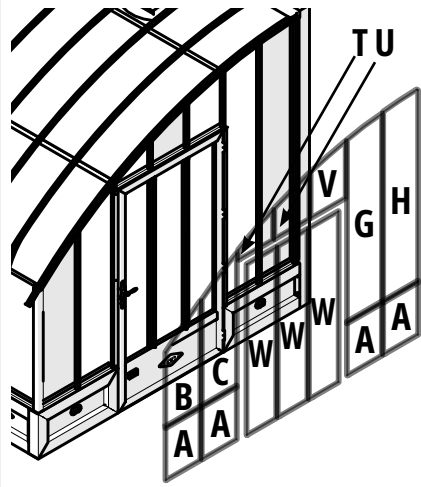

Roof glazing

See glass Z (see page 53)

Installation of 2 S hooks (44) for the glasshouses with a 40 cm base:



Installation of the W clips (SAL1), 2 possibilities:



Possibility 1

Possibility 2

INSTALLING THE WALL AND ROOF GLAZING - RIDGE HEIGHT 3.10 M

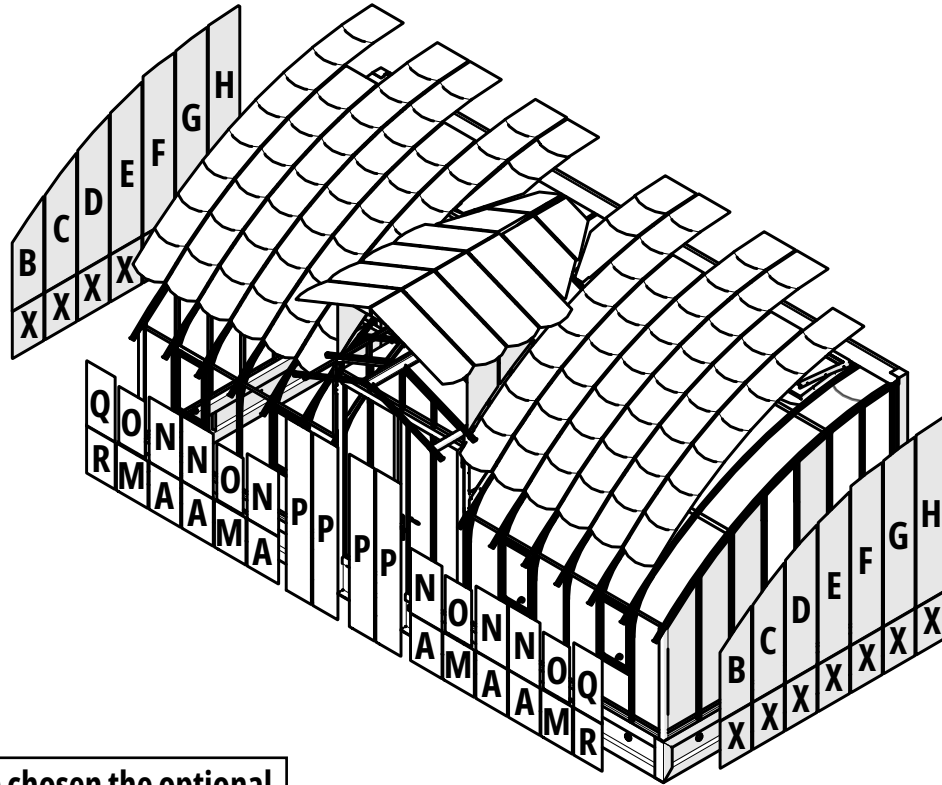

If you have chosen the optional side door:

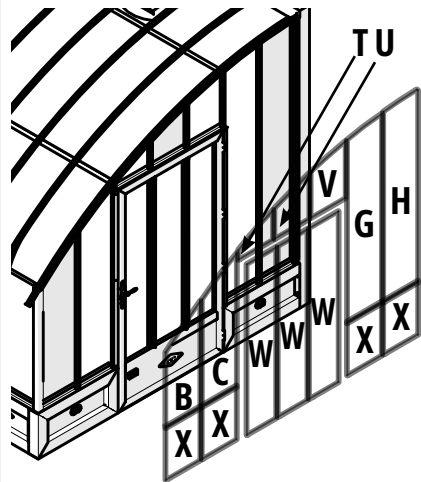

Roof glazing

See glass Z (see page 53)

Installation of 2 S hooks (44) for the glasshouses with a 40 cm base:



Installation of the W clips (SAL1), 2 possibilities:



Possibility 1

Possibility 2

Letter	Base H. 40 cm		Base H. 87 cm	
	Size (in mm)	Number of clips	Size (in mm)	Number of clips
A	870 x 358	4	/	/
B	960 x 358	4	960 x 358	4
C	1200 x 358	4	1200 x 358	4
D	1390 x 358	4	1390 x 358	4
E	1530 x 358	4	1530 x 358	4
F	1635 x 358	6	1635 x 358	6
G	1700 x 358	6	1700 x 358	6
H	1735 x 358	6	1735 x 358	6
M	420 x 358	2	/	/
N	645 x 358	4	1030 x 358	4
O	985 x 300	4	945 x 300	4
P	2120 x 285	6	1635 x 285	6
Q	645 x 324	4	1030 x 324	6
R	870 x 324	4	/	/
T	645 x 358 x 457	4	645 x 358 x 457	4
U	660 x 358 x 785	4	660 x 358 x 785	4
V	890 x 358 x 795	4	890 x 358 x 795	4
W	1531 x 304	6	1053 x 304	6
X	870 x 358	4	398 x 358	2
Z	400 x 358	2	400 x 358	2

INSTALLING THE ROOF GLAZING - SMALL GLASS PANES (GLASS TILES)

- 1 - Place a rounded glass (Z) on the lower end of the roof, at the end of the profiles.
- 2 - Install 4 clips (SAL1) on the first glass pane (two on the right, two on the left).
- 3 - Place 2 hooks (44) on the top of the glass pane (one on the right, one on the left).
- 4 - Place the second glass, then two clips (SAL1) centered on the height of the glass then two hooks (44). Repeat this step all the way to the top of the roof.
- 5 - Install the second row, the third row, etc. in the same way, ...

Hooks on the edges of the glass

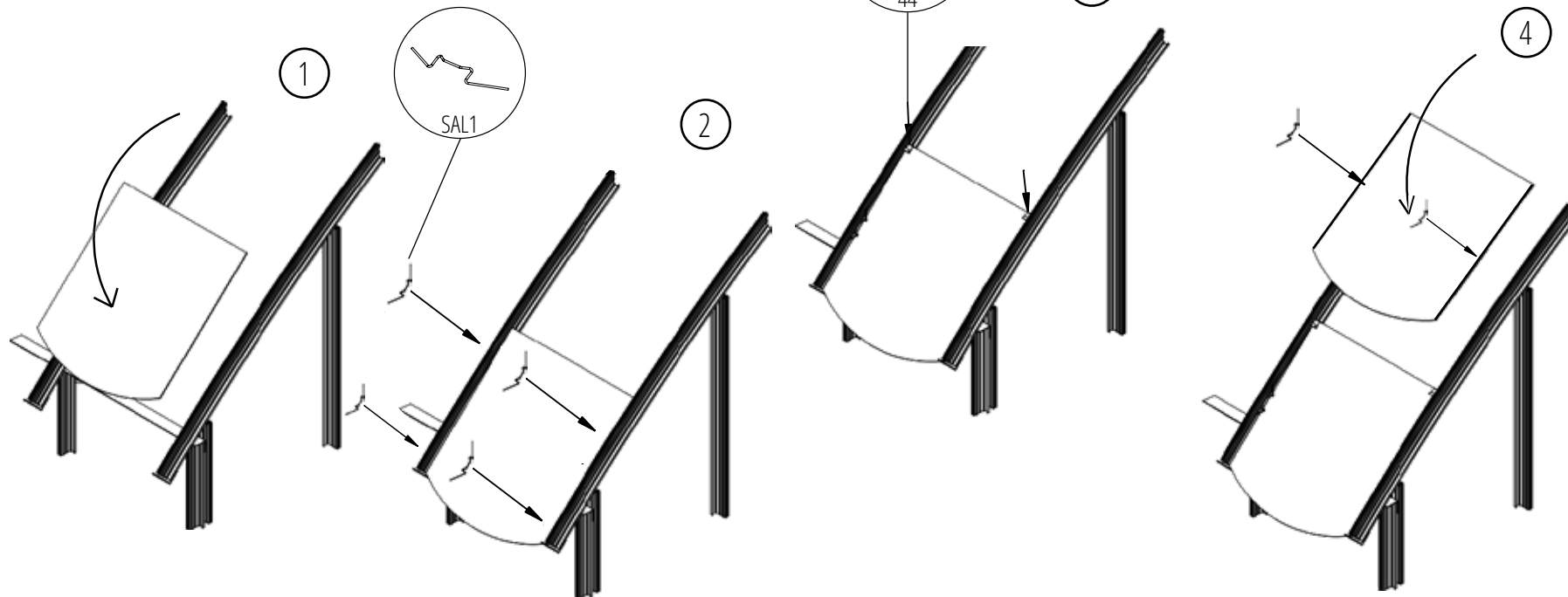
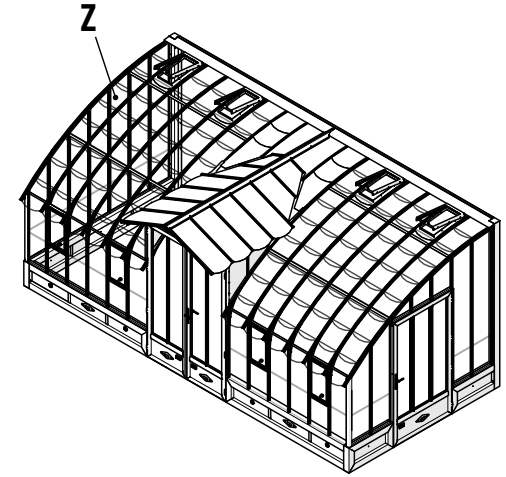
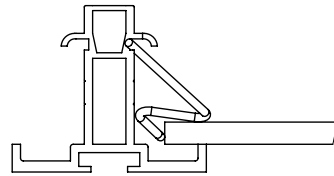
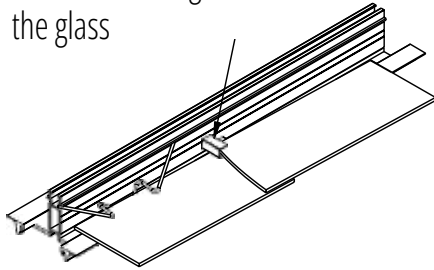

FINISHING TOUCHES

At this stage of assembly, please check that all the greenhouse hardware is correctly installed and bolted.

Fix the decorative mouldings

Fix the mouldings with screws (27) and nut cap (28).

Place the LAMS logo on the left-hand side upper part of the door aluminium panel, below the handle and lock.

The number of lead-motif and rose mouldings varies according to the size of your glasshouse. Screw them on the base plates, in the order you prefer. However, we recommend placing a leaf-motif moulding on the door and then alternate roses and leaf motifs around the glasshouse.



Leaf moulding



Rose moulding



Logo

Door frame covers

In order to hide the hinges and screws of the door frame, install door frame covers (S) on either side of the door with self-drilling screws (43).

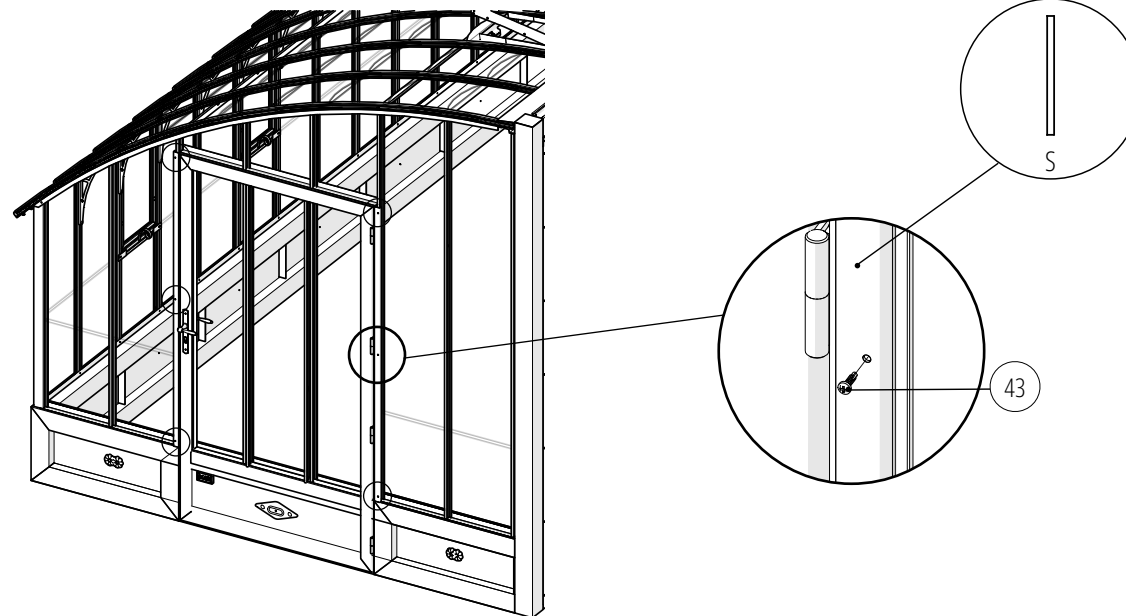

SHADING SYSTEM

With our shading system, regulate the temperature in the glasshouse and protect plants and seedlings from direct sunrays (magnifying effect of sunrays through glass).

Purchase a shading system for your glasshouse from our website : www.serres-lams.com





French glasshouse designer & manufacturer since 1993

*DOVIRIS - 43 Avenue Georges Clémenceau 85120 LA CHÂTAIGNERAIE - FRANCE - www.serres-lams.com
Non-contractual photos and illustrations.*

